



Agilent InfinityLab LC Series
InfinityLab Assist
User Manual



Notices

Document Information

The information in this document also applies to 1260 Infinity II and 1290 Infinity II modules.

Document No: D0113047 Rev. A.04
Edition: 03/2026

Copyright

© Agilent Technologies, Inc.
2024-2026

No part of this manual may be reproduced in any form or by any means (including electronic storage and retrieval or translation into a foreign language) without prior agreement and written consent from Agilent Technologies, Inc. as governed by United States and international copyright laws.

Agilent Technologies
Hewlett-Packard-Strasse 8
76337 Waldbronn, Germany

Warranty

The material contained in this document is provided "as is," and is subject to being changed, without notice, in future editions. Further, to the maximum extent permitted by applicable law, Agilent disclaims all warranties, either express or implied, with regard to this manual and any information contained herein, including but not limited to the implied warranties of merchantability and fitness for a particular purpose. Agilent shall not be liable for errors or for incidental or consequential damages in connection with the furnishing, use, or performance of this document or of any information contained herein. Should Agilent and the user have a separate written agreement with warranty terms covering the material in this document that conflict with these terms, the warranty terms in the separate agreement shall control.

Technology Licenses

The hardware and/or software described in this document are furnished under a license and may be used or copied only in accordance with the terms of such license.

Restricted Rights Legend

U.S. Government Restricted Rights. Software and technical data rights granted to the federal government include only those rights customarily provided to end user customers. Agilent provides this customary commercial license in Software and technical data pursuant to FAR 12.211 (Technical Data) and 12.212 (Computer Software) and, for the Department of Defense, DFARS 252.227-7015 (Technical Data - Commercial Items) and DFARS 227.7202-3 (Rights in Commercial Computer Software or Computer Software Documentation).

Safety Notices

CAUTION

A **CAUTION** notice denotes a hazard. It calls attention to an operating procedure, practice, or the like that, if not correctly performed or adhered to, could result in damage to the product or loss of important data. Do not proceed beyond a **CAUTION** notice until the indicated conditions are fully understood and met.

WARNING

A **WARNING** notice denotes a hazard. It calls attention to an operating procedure, practice, or the like that, if not correctly performed or adhered to, could result in personal injury or death. Do not proceed beyond a **WARNING** notice until the indicated conditions are fully understood and met.

Contents

In This Guide... 6

1 Introduction 7

- Overview of the InfinityLab Assist 8
- Features of the InfinityLab Assist 10
- Hardware Concept 11
- Software Concept 13

2 Site Requirements and Specifications 14

- InfinityLab Assist Hardware and Software Requirements 15
- Site Requirements 18
- Specifications of the InfinityLab Assist Hub (G7180A) 21
- Specifications of the InfinityLab Assist Interface (G7179A) 23

3 Installation 25

- Hardware Installation 26
- Software Installation 34
- Software Update 36

4 Using the Module 40

- General Information 41
- Using the Drivers with this Module 46
- Using the InfinityLab Assist Interface 49

5 Using the Software 51

- Using the Assist Control Software Browser User Interface 52
- Login and Logout 54
- User Interface Overview 57
- How to Work with the Software 62
- About InfinityLab Assist Control Software 93

- 6 Configuring the Assist Control Software 95**
- 7 Troubleshooting and Diagnostics 96**
 - Status Indicators 97
 - Block for Service 98
 - Overview of Available Tests and Tools 99
 - Maintenance and Troubleshooting Tools 104
- 8 Maintenance Tasks 106**
 - Safety Information Related to Maintenance 107
 - Overview of Maintenance 109
 - Cleaning the Module 110
 - Remove and Install the Display Holder 111
 - Troubleshooting an Unresponsive Assist Interface 114
- 9 Parts and Materials for Maintenance 116**
 - Standard Parts for Maintenance 117
 - Accessory Kits 118
- 10 Identifying Cables 119**
 - Cable Overview 120
 - Analog Cables 122
 - Remote Cables 124
 - BCD Cables 128
 - CAN/LAN Cables 130
 - RS-232 Cables 131
 - USB 132
- 11 Hardware Information 133**
 - General Hardware Information 134
 - Module-Specific Hardware Information 146
- 12 LAN Configuration 149**
 - What You Have to Do First 149
 - TCP/IP Parameter Configuration 150
 - Configuration Switch and Mode Selection 151

Manual Configuration 152
PC Setup for Local Configuration 153

13 Appendix 155

General Safety Information 156
Waste Electrical and Electronic Equipment (WEEE) Directive 163
Radio Interference 164
Sound Emission 165
Agilent Technologies on Internet 166



In This Guide...

This manual covers the following products:

- Agilent InfinityLab Assist Hub (G7180A)
- Agilent InfinityLab Assist Interface (G7179A)
- Agilent InfinityLab Assist Control Software (M8780AA)



1 Introduction

This chapter gives an introduction to the module and an instrument overview.

Overview of the InfinityLab Assist 8

Features of the InfinityLab Assist 10

Hardware Concept 11

Software Concept 13

Overview of the InfinityLab Assist

The Agilent InfinityLab Assist (G7180A/G7179A) is a user interface, computing unit and control software which is part of every new 1260/1290 Infinity III HPLC System or can be added to every standard 1260/1290 Infinity II HPLC System. It is also compatible with the 1260/1290 Infinity II/III Bio and 1260 Infinity II/III Bio-inert HPLC Systems from Agilent.

The InfinityLab Assist Control Software (M8780AA) runs on the Assist Hub and is displayed on the Assist Interface for local control of the instrument. In the 1260 and 1290 Infinity II/III HPLC systems it is used as an interface to overview and control all instrument parameter. With instrument trends, early maintenance feedback counters, and dashboarding, it helps to get a deeper understanding of the instrument. It also serves as a preventive maintenance tool.

The Agilent InfinityLab Assist simplifies the process of troubleshooting and maintenance by giving assistance at the instrument.

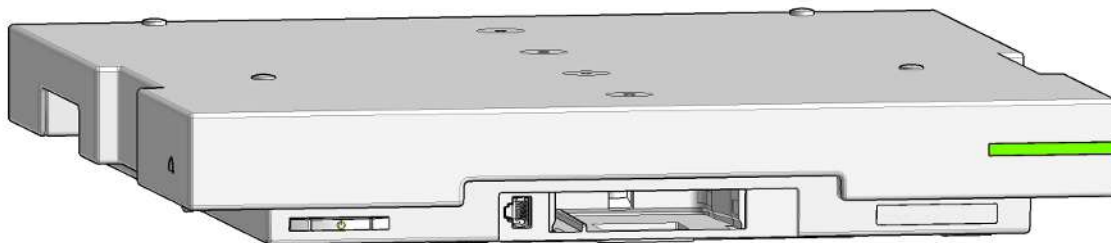

Figure 1: InfinityLab Assist Hub (G7180A)

Introduction

Overview of the InfinityLab Assist

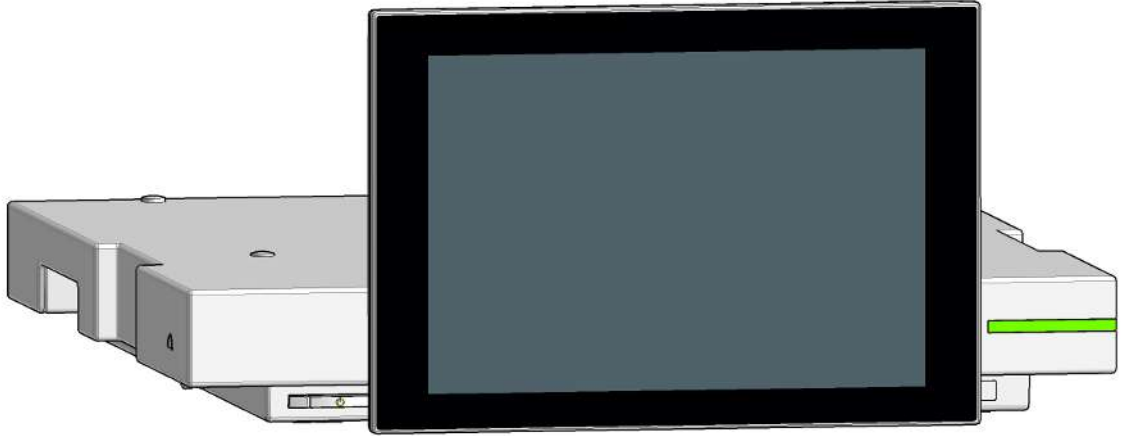

Figure 2: InfinityLab Assist Interface (G7179A)



Figure 3: InfinityLab Assist Control Software (M8780AA)

Features of the InfinityLab Assist

- Is part of every new 1260/1290 Infinity III HPLC system or can be added to every standard 1260/1290 Infinity II HPLC System.
- Provides a state of the art user interface for an intuitive and fast overview and control of the HPLC instrument parameters.
- Enables automation of tedious and repetitive workflows such as instrument start up and shutdown to eliminate errors and maximize lab efficiency.
- Supports maximum up time of the instrument by providing assisted troubleshooting and predictive maintenance directly at the instrument.

Hardware Concept



Figure 4: InfinityLab Assist overview

The InfinityLab Assist Hub and InfinityLab Assist Interface do not have any flow path. The concept of the Assist Interface with display arm is to create an ergonomic user interface for all users. The home position of the Assist Interface is in its highest position against the solvent cabinet or the InfinityLab Level Sensing cabinet. The Assist Interface can be moved to a lower position to interact with users who have difficulty operating the user interface in the home position.

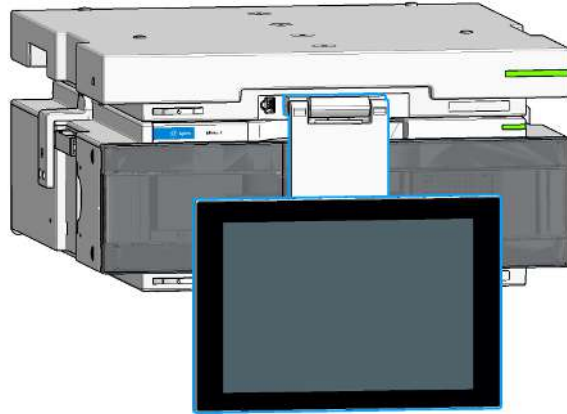

The Assist Interface on the display arm can also be angled for optimum viewing of the screen. This is especially useful during maintenance.

The section [Module-Specific Hardware Information](#) on page 146 describes the main hardware components of the InfinityLab Assist Hub and InfinityLab Assist Interface in detail.

Software Concept

The InfinityLab Assist Control Software runs on the InfinityLab Assist Hub and is displayed on the InfinityLab Assist Interface for local control of the instrument. The user interface is designed to be intuitive and to support the laboratory user as an assistant with everyday work. The software running on the Assist Hub can also be accessed remotely via most browsers. For more information, refer to [Using the Assist Control Software Browser User Interface](#) on page 52.

The Assist Control Software provides an overview of the current processes of the instrument, from the analysis status to the individual signal readouts, such as system pressure. The software also stores instrument usage data to get a deeper understanding of the instrument. Instrument *Insights* will help the user to understand the instrument efficiency and notify the user when upcoming maintenance is recommended. The software also offers maintenance procedures that guide the user step by step through the maintenance process. If a problem occurs with the HPLC system, the software provides assistance to get the instrument up and running again via the advanced online help, troubleshooting and Assisted Troubleshooting.

The Assist Control Software also supports the user with tedious workflows such as preparing the system for analysis or cleaning and shutting down the system after use. These tasks can be scheduled to run automatically when the user needs them.

NOTE

For secure use of the InfinityLab Assist, appropriate isolation of the lab network must be ensured.



2

Site Requirements and Specifications

This chapter provides information on environmental requirements, physical and performance specifications.

InfinityLab Assist Hardware and Software Requirements 15

Site Requirements 18

Power considerations 18

Power Cords 18

Bench Space 19

Environment 20

Specifications of the InfinityLab Assist Hub (G7180A) 21

Specifications of the InfinityLab Assist Interface (G7179A) 23

InfinityLab Assist Hardware and Software Requirements

The following PC and software requirements are needed for viewing the browser user interface and running the chromatography data system (CDS).

Table 1: Software Requirements

Specification Description	Details
Operating system name, version	Windows 10 or 11, Enterprise or Professional, 64-bit
Web browser	Chromium-based browser (Chrome, Edge, etc.) with a version higher than 132 Safari-based browser with a version higher than 17.5.1

Table 2: Network Requirements

Specification Description	Supported
Network type, bandwidth, speed, protocol, etc.	Internet Protocol Version 4 (TCP/IPv4)
IP Address	Static or DHCP Reservation

The InfinityLab Assist is compatible with the following CDS software versions:

Table 3: Compatible Software Version

Supported CDS Software	Minimum Software Versions
OpenLab CDS 2.x	OpenLab CDS 2.6 OpenLab CDS 2.7 OpenLab CDS 2.8 OpenLab CDS 2.8 Update 3 for Client/Server (provides browser access)
MassHunter	LC-(Q)TOF MH 12.1 LC-TQ MH 12.2
ChemStation	OpenLab ChemStation C.01.10 OpenLab ChemStation LTS C.01.11

Site Requirements and Specifications

InfinityLab Assist Hardware and Software Requirements

Supported CDS Software	Minimum Software Versions
Empower	Empower 3 Feature Release 4, or higher Agilent Driver for Waters Empower 4.1
Chromeleon	Chromeleon 7.2.10 MUF, or higher Chromeleon 7.3.1 Agilent Driver for Thermo Fisher Chromeleon 3.2 (LC Driver 3.9)

Table 4: InfinityLab Assist Supported Modules

Product Number	Description
G1170A	1290 Valve Drive
G1390B	Universal Interface Box
G4756A	Sample ID Reader
G5654A	1260 Bio-inert Pump
G5668A	1260 Bio-inert Multisampler
G6160B	Pro iQ MS
G6170A	Pro iQ Plus MS
G6465B	Ultivo Triple Quadrupole LC/MS System
G6475A	Triple Quadrupole LC/MS System
G6495D	Triple Quadrupole LC/MS
G7104A	1290 Flexible Pump
G7104C	1260 Flexible Pump
G7110B	1260 Isocratic Pump
G7111A	1260 Quaternary Pump VL
G7111B	1260 Quaternary Pump
G7112B	1260 Binary Pump
G7114A	1260 VWD
G7114B	1290 VWD
G7115A	1260 DAD WR
G7116A	1260 Multicolumn Thermostat
G7116B	1290 Multicolumn Thermostat
G7117A	1290 DAD FS
G7117B	1290 DAD

Site Requirements and Specifications

InfinityLab Assist Hardware and Software Requirements

Product Number	Description
G7117C	1260 DAD HS
G7120A	1290 High-Speed Pump
G7121A	1260 Fluorescence Detector
G7121B	1260 FLD Spectra
G7123B	1290 Fluorescence Detector
G7129A	1260 Vialsampler
G7129B	1290 Vialsampler
G7129C	1260 Vialsampler
G7130A	Integrated Column Compartment
G7131A	1290 Bio Flexible Pump
G7131C	1260 Bio Flexible Pump
G7132A	1290 Bio High-Speed Pump
G7137A	1290 Bio Multisampler
G7137B	1290 Hybrid Multisampler
G7162A	1260 RID
G7162B	1290 RID
G7165A	1260 MWD
G7167A	1260 Multisampler
G7167B	1290 Multisampler
G7167C	1260 Hybrid Multisampler
G7175A	InfinityLab Level Sensing
Clusters	2D-LC Cluster, HDR-DAD Cluster, Pump Valve Cluster, Valve Thermostat Cluster

Site Requirements

Power considerations

The Assist Hub (G7180A) power supply has wide ranging capability. It accepts any line voltage in the range described in [Specifications of the InfinityLab Assist Hub \(G7180A\)](#) on page 21. Consequently there is no voltage selector in the rear of the module. There are also no externally accessible fuses, because automatic electronic fuses are implemented in the power supply.

WARNING**Inaccessible power plug.**

In case of emergency it must be possible to disconnect the instrument from the power line at any time.

- Make sure the power connector of the instrument can be easily reached and unplugged.
 - Provide sufficient space behind the power socket of the instrument to unplug the cable.
-

WARNING**Incorrect line voltage at the module**

Shock hazard or damage of your instrument can result if the devices are connected to line voltage higher than specified.

- Connect your module to the specified line voltage.
-

Power Cords

Country-specific power cords are available for the module. The female end of all power cords is identical. It plugs into the power-input socket at the rear. The male end of each power cord is different and designed to match the wall socket of a particular country or region.

Agilent makes sure that your instrument is shipped with the power cord that is suitable for your particular country or region.

WARNING**Unintended use of power cords**

Using power cords for unintended purposes can lead to personal injury or damage of electronic equipment.

- Never use a power cord other than the one that Agilent shipped with this instrument.
- Never use the power cords that Agilent Technologies supplies with this instrument for any other equipment.
- Never use cables other than the ones supplied by Agilent Technologies to ensure proper functionality and compliance with safety or EMC regulations.

WARNING**Absence of ground connection**

The absence of ground connection can lead to electric shock or short circuit.

- Never operate your instrumentation from a power outlet that has no ground connection.

WARNING**Electrical shock hazard**

Solvents may damage electrical cables.

- Prevent electrical cables from getting in contact with solvents.
- Exchange electrical cables after contact with solvents.

Bench Space

The module dimensions and weight (see [Specifications of the InfinityLab Assist Hub \(G7180A\)](#) on page 21) allow you to place the module on almost any desk or laboratory bench. It needs an additional 2.5 cm (1.0 inches) of space on either side and approximately 8 cm (3.1 inches) in the rear for air circulation and electric connections

If the bench shall carry a complete HPLC system, make sure that the bench is designed to bear the weight of all modules.

The module should be operated in a horizontal position.

Environment

Your module will work within specifications at ambient temperatures and relative humidity as described in [Specifications of the InfinityLab Assist Hub \(G7180A\)](#) on page 21.

CAUTION

Condensation within the module

Condensation can damage the system electronics.

- Do not store, ship or use your module under conditions where temperature fluctuations could cause condensation within the module.
 - If your module was shipped in cold weather, leave it in its box and allow it to warm slowly to room temperature to avoid condensation.
-

Specifications of the InfinityLab Assist Hub (G7180A)

Table 5: Physical specifications of the InfinityLab Assist Hub (G7180A)

Type	Specification	Comments
Weight	4.4 kg (9.7 lbs)	
Dimensions (height x width x depth)	61 x 396 x 441 mm (2.4 x 15.6 x 17.4 inches)	Without InfinityLab Assist Interface and without holder. Including features which will be used to align modules in the stack.
Line voltage	100–240 V~	Wide-ranging capability
Line frequency	50 / 60 Hz	
Power consumption	200 VA	
Ambient operating temperature	4–45 °C (39–113 °F)	
Ambient non-operating temperature	-40–70 °C (-40–158 °F)	
Humidity	< 95% r.h. at 40 °C (104 °F)	Non-condensing
Operating altitude	Up to 3000 m (9842 ft)	
Safety standards: IEC, EN, CSA, UL	Overvoltage category II, Pollution degree 2	For indoor use only
ISM Classification	ISM Group 1 Class B	According to CISPR 11

Site Requirements and Specifications

Specifications of the InfinityLab Assist Hub (G7180A)

Table 6: Performance specifications of the InfinityLab Assist Hub (G7180A)

Type	Specification	Comments
Designed for use with Agilent InfinityLab Assist	Intuitive User Interface, Automated Workflows, Predictive Maintenance & Assisted Troubleshooting	
Instrument control	LC & CE Drivers 3.8 or above InfinityLab Assist (G7180A) with software version 1.0 (E.01.00)	For details about supported software versions refer to the compatibility matrix of your version of the LC & CE Drivers
Communication	4x USB A Ports w/ USB 2.0 1x USB C Port w/ USB 3.1 and Power Delivery (27 W) 1x USB C Port w/ USB 3.1 5x LAN Ports, RJ45, 1 GBit/s (1x Network, 4x Module connection) 2x CAN Port, RJ45 1x LAN Port, RJ45, 1 GBit/s w/ PoE (IEEE 802.3 bt Type 3 Class 5; 45 W) for Assist Interface	
Maintenance and safety-related features	Extensive diagnostics, error detection and display with Agilent InfinityLab Assist Leak detection, safe leak handling, leak output signal for shutdown of pumping system, and low voltages in major maintenance areas	
GLP features	Early maintenance feedback (EMF) for continuous tracking of instrument usage with user-settable limits and feedback messages. Electronic records of maintenance and errors	
Housing	All materials recyclable	

Specifications of the InfinityLab Assist Interface (G7179A)

Table 7: Physical specifications of the InfinityLab Assist Interface (G7179A)

Type	Specification	Comments
Weight	1.1 kg (2.4 lbs)	
Dimensions (height × width × depth)	178.0 × 259.0 × 39.5 mm (7.0 × 10.2 × 1.6 inches)	
Line voltage	IEEE 802.3bt Class 5 (42.5 - 57 VDC)	
Line frequency	N/A	
Power consumption	IEEE 802.3bt Class 5 (42.5 - 57 VDC, 0.5 A)	
Ambient operating temperature	+4 – 40 °C (39 – 104 °F)	
Ambient non-operating temperature	-20 – 70 °C (-4 – 158 °F)	
Humidity	relative maximum humidity of 90 % (non-condensing)	
Operating altitude	Up to 3000 m (9842 ft)	
Safety standards: IEC, EN, CSA, UL	Overvoltage category II, Pollution degree 2	For indoor use only
ISM classification	ISM Group 1 Class B	According to CISPR 11

Site Requirements and Specifications

Specifications of the InfinityLab Assist Interface (G7179A)

Table 8: Performance specifications of the InfinityLab Assist Interface (G7179A)

Type	Specification	Comments
Designed for use with Agilent InfinityLab Assist	Intuitive User Interface, Automated Workflows, Predictive Maintenance & Assisted Troubleshooting	
Instrument control	LC & CE Drivers 3.8 or above InfinityLab Assist (G7180A) with software version 1.0 (E.01.00)	For details about supported software versions refer to the compatibility matrix of your version of the LC & CE Drivers
Communication	1× RJ45 Ethernet w/ Power over Ethernet (PoE) 2× USB A Ports w/ USB 2.0 (max. 2.5 W each) 1× USB Type-C® Port w/ USB 3.1 (max. 4.5 W each)	PoE includes communication and power supply Ethernet cables used to connect the device shall meet Cat 5e or higher
Maintenance and safety-related features	Extensive diagnostics, error detection and display with Agilent InfinityLab Assist Leak detection, safe leak handling, leak output signal for shutdown of pumping system, and low voltages in major maintenance areas	
GLP features	Early maintenance feedback (EMF) for continuous tracking of instrument usage with user-settable limits and feedback messages. Electronic records of maintenance and errors.	
Housing	All materials recyclable	



3 Installation

Hardware Installation 26

Unpacking the Module 26

Stacking the InfinityLab Assist 27

Installing the Display Holder 29

Device Connection 32

Software Installation 34

Getting Started 34

Software Update 36

Update Unsupported Firmware 39

Hardware Installation

Unpacking the Module

Damaged Packaging

If the delivery packaging shows signs of external damage, please call your Agilent Technologies sales and service office immediately. Inform your service representative that the instrument may have been damaged during shipment.

CAUTION

"Defective on arrival" problems

If there are signs of damage, please do not attempt to install the module. Inspection by Agilent is required to evaluate if the instrument is in good condition or damaged.

- Notify your Agilent sales and service office about the damage.
 - An Agilent service representative will inspect the instrument at your site and initiate appropriate actions.
-

Condensation

CAUTION

Condensation within the module

Condensation can damage the system electronics.

- Do not store, ship or use your module under conditions where temperature fluctuations could cause condensation within the module.
 - If your module was shipped in cold weather, leave it in its box and allow it to warm slowly to room temperature to avoid condensation.
-

Stacking the InfinityLab Assist

WARNING

Risk of injury due to extended positioning of the holder in stand-by mode

If the arm of the holder is extended, there is a risk of catching on the InfinityLab Assist Interface. People passing by can get injured and the InfinityLab Assist Interface or other parts of the stack can be damaged. Solvent bottles in the solvent cabinet or the InfinityLab Level Sensing module above the InfinityLab Assist Hub can fall down if they are exposed to mechanical shocks.

- After use, return the InfinityLab Assist Interface to the home position: Move the InfinityLab Assist Interface to the highest position against the solvent cabinet or InfinityLab Level Sensing module.
-

WARNING

Improper installation of safety clips

If the InfinityLab Assist Interface is moved over the holder and the safety clips are not properly installed, the InfinityLab Assist Hub and Solvent Cabinet/Solvent Level Sensing can be lifted. This can result in personal injury and damage of the modules.

- Attach a safety clip to the right and left of the InfinityLab Assist Hub. Screw the safety clips into the module below the InfinityLab Assist Hub.
-

CAUTION

Improper installation of Display Holder

If the Display Holder with the attached InfinityLab Assist Interface is not properly inserted into the InfinityLab Assist Hub, the InfinityLab Assist Interface may fall out and get damaged.

- Install the Display Holder correctly on the InfinityLab Assist Hub according to the instructions.
-

Stacking the InfinityLab Assist

The InfinityLab Assist Hub must be stacked as the uppermost module in a configuration with a standard solvent cabinet.

- 1 Stack the Assist Hub directly below the solvent cabinet and above the next highest module.

Installation

Hardware Installation

- 2 Attach the safety clips to the right and left of the Assist Hub.

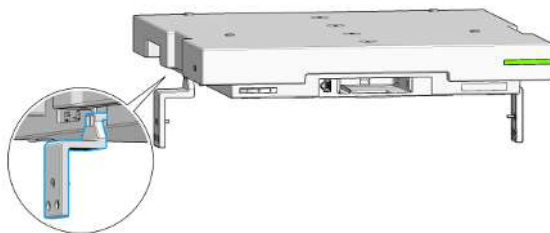

- 3 Screw the safety clips into the module below.

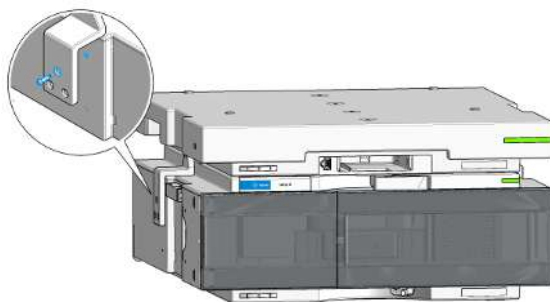

NOTE

In a Flex Bench installation, the Assist Hub must always be installed on a shelf, stacked with an additional module and secured with safety clips.

Installing the Display Holder

WARNING

Risk of injury due to extended positioning of the holder in stand-by mode

If the arm of the holder is extended, there is a risk of catching on the Assist Interface. People passing by can get injured and the Assist Interface or other parts of the stack can be damaged. Solvent bottles in the solvent cabinet or the InfinityLab Level Sensing module above the Assist Hub can fall down if they are exposed to mechanical shocks.

- After use, return the Assist Interface to the home position: Move the Assist Interface to the highest position against the solvent cabinet or InfinityLab Level Sensing module.
-

CAUTION

Improper installation of Display Holder

If the Display Holder with the attached Assist Interface is not properly inserted into the Assist Hub, the Assist Interface may fall out and get damaged.

- Install the Display Holder correctly on the Assist Hub according to the instructions.
-

Installation

Hardware Installation

- 1 Insert the Display Holder into the Assist Interface.

CAUTION

Improper installation of the Assist Interface

If the Assist Interface does not properly click into the Display Holder, then there is a risk of personal injury due to the Assist Interface falling down.

- Install the Assist Interface correctly.

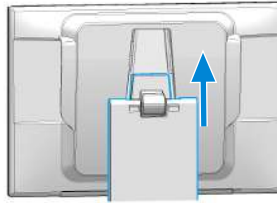

NOTE

If you insert the Display Holder correctly, you will hear a click when it snaps into the Assist Interface.

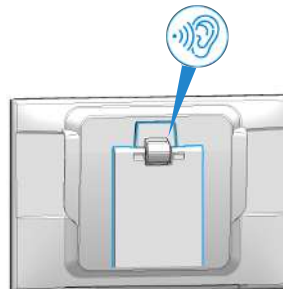

Installation

Hardware Installation

- 2 Insert the Assist Interface and Display Holder into the Assist Hub garage.

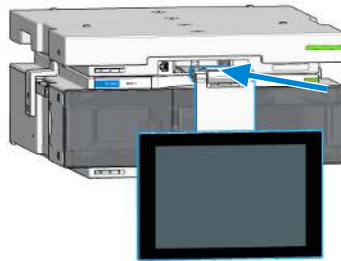
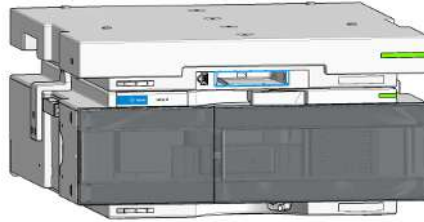

NOTE

If you insert the Display Holder correctly, you will hear a click when it snaps into the Assist Hub.



- 3 The Assist Interface can be moved into a variety of positions during use. After use, return the Assist Interface to the home position.

Device Connection

CAUTION

Damage to the module

The Assist Hub consists of a Power over Ethernet (PoE) connector. A typical LAN cable could result in issues powering the Assist Interface.

- Use a Power over Ethernet (PoE) cable for the Power over Ethernet (PoE) connector of the Assist Hub.

Preparations

- All modules in the system are turned off.
- 1 Connect the Power over Ethernet (PoE) cable to the connection on the back of the Assist Interface. Install the other end of the cable at the front of the Assist Hub.

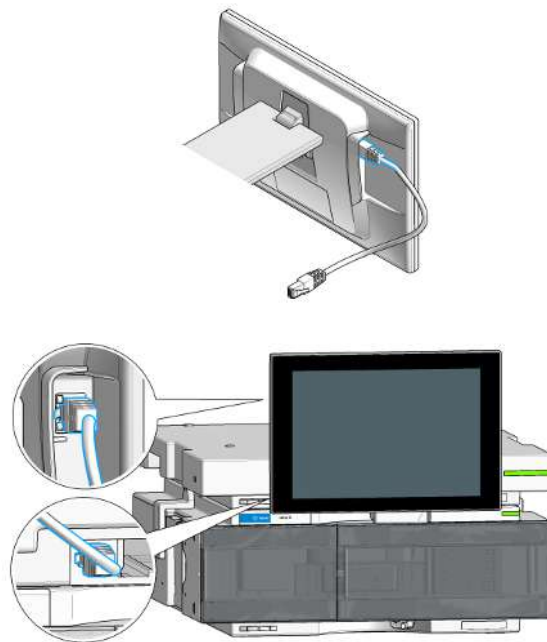

- 2 At the back of the Assist Hub, insert a CAN cable into the CAN port of the module to communicate over the CAN bus.
- 3 Establish LAN connections to the Assist Hub with all detectors and pumps in the stack. Insert 5023-0203 (Cross-over network cable, shielded, 3 m) into the ports labeled Module LAN.

Installation

Hardware Installation

- 4 Install a Lab LAN for communication purposes. **Lab LAN** is reserved for the system connection to the PC or laboratory LAN infrastructure.
- 5 Install the power cable into the Assist Hub and then attach it to the power source.

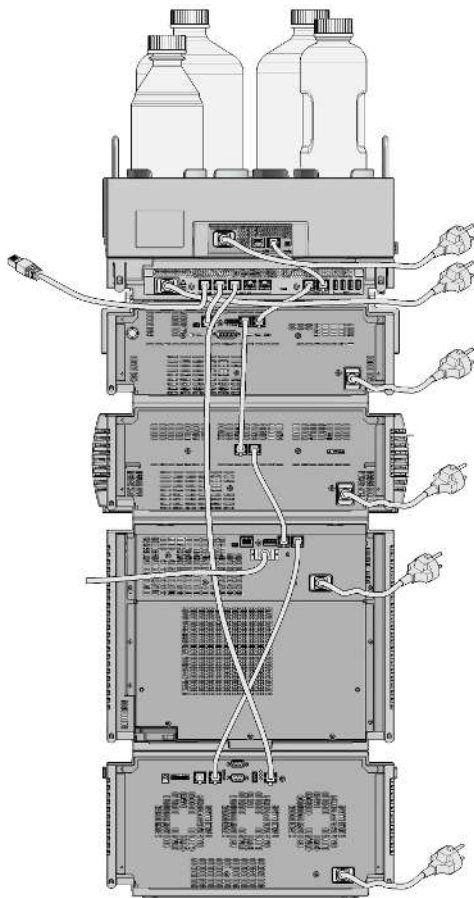

Figure 5: The figure shows a 1290 Infinity III System with proper cabling and an ERI cable to a third-party device.

- 6 Turn on all the modules including the Assist Interface.

Software Installation

Getting Started

Unlocking the InfinityLab Assist Interface

When the Assist is started for the first time, a locked **Ambient** screen appears on start-up. To unlock the **Ambient** screen during installation, use the administration PIN supplied with the instrument.

NOTE

The PIN can be found on the Instrument label on the right-hand side of the module.

Once unlocked, the Onboarding guide is displayed as the first screen.

Onboarding Guide

The Onboarding Guide presents the most important features of the Assist. You can skip this guide and revisit it later on from  **Settings > About > Onboarding Guide**.

When using Authentication, each user (for example, Lab Analyst, Maintenance Technician) will be introduced to the Onboarding Guide.

The administrator will also see the following settings during the Onboarding Guide:

- **CDS Required:** This function enables the Assist to be used in a regulated environment. Enable/disable the feature depending on the existing Chromatography Data System (CDS) and LC & CE Driver. When the feature is activated, every action that changes method settings is logged in the CDS.
- **Set Date, Time & Region:** This allows the Assist settings for Date, Time & Region to be updated.
- **Connection Settings:** Allows you to configure the IP address of the Assist Hub.

Installation

Software Installation

- **Share Usage Data:** You can decide to participate in the Agilent Improvement Program. Please read the participation text for complete information. Participating will upload usage data randomized and anonymously when the Assist Hub is connected to the Internet.

Welcome to the Ambient Screen

The **Ambient** screen is displayed when InfinityLab Assist is locked. It displays live data without the need of unlocking InfinityLab Assist.

To change the layout, you need the permission **Edit ambient screen layout**. The roles **Agilent Service Technician** or **Administrator** have this permission by default.

For a quick start, select the **Default Layout** in the editing mode. You can edit the ambient screen when the Assist Interface is locked again.

For details how to edit the ambient screen, refer to [Designing the Ambient Screen](#) on page 62.

Software Update

NOTE

An update of the Assist Control Software may require a concurrent update of the instrument's firmware. Instruments with firmware versions below the minimum required version cannot be controlled with the Assist Hub (see **Update Unsupported Firmware** on page 39).

If the Assist Hub is connected to the Internet and has an Assist Control Software Version of 2.0 or higher, then the software generates a notification when an update is available.

Optional: Download Software Updates Manually

You can manually check for software updates. Updates are available at:

<https://update.pl29.agilent.com/infinitylab>

Check regularly for new updates. You can use a USB storage media to store the update files. It must be of type exFAT, FAT32, EXT4. Both, the Assist Interface and the Assist Hub consist of a USB connector.

If you start InfinityLab Assist remotely in a Web browser, you can also store the update files to a known location on the PC and select software or firmware updates manually. A Chromium-based browser is required to open the Assist Control Software.

To be able to update software and firmware as described you need the permission **Install software/firmware updates**. The roles **Agilent Service Technician** or **Administrator** have this permission by default.

Check for Updates

- 1 Select  from the main toolbar.
The Settings screen is displayed. A red dot on the General tab indicates that updates are available.
- 2 On the General tab, select **Update**.
The Update wizard is started. If **Automatically Check for Updates** is active and sources are accessible, the available software and firmware updates are listed.
- 3 Otherwise, select **Check for Updates**.
If update sources are accessible, the available software and firmware updates are listed.
- 4 If you started InfinityLab Assist remotely in a Web browser, you can also select **Browse** to search the file system yourself and select software or firmware updates manually.

Select Update

- 1 Select the desired update.
- 2 Select **Continue With Selection**.
If the **Update** wizard cannot open the file, you need to check for updates again. Otherwise, the content of the update file is displayed.
- 3 If there are firmware updates available and the modules are connected and turned on, you can choose from two options.
 - **Only Mandatory**
This tab lists all modules with firmware versions below the minimum version required with their current and target firmware version.
If all modules have at least the minimum firmware version required, no modules are listed here.
 - **Latest**
This tab lists all modules with supported firmware for which newer firmware versions are available with their current and target firmware versions.

Installation

Software Update

- 4 To filter out changes that do not apply to modules in your instrument, select the **HW configuration relevant changes only** check box
- 5 To display the release notes, select \checkmark .

Install Update (Automatic Restart)

- 1 Select the **Automatic restart after update** check box.
- 2 Select **Install Update**.

The **Update** wizard uploads the update file. A progress indicator shows the progress. When the upload is finished successfully, the Assist Hub restarts after 60 seconds. If the instrument is then busy, the restart will be executed when the instrument is idle again.

The buttons **Restart Later** and **Restart Now** are displayed. The **Restart Now** button is only active when the instrument is idle.

- 3 To postpone the restart, select **Restart Later**.

The Assist Hub will restart with the installed update after the Assist Hub has been turned off and on again.

- 4 To restart immediately, select **Restart Now**.

The Assist Hub restarts with the installed update. The firmware updates thereafter.

Install Update (Manual Restart)

- 1 Clear the **Automatic restart after update** check box.
- 2 Select **Install Update**.

The **Update** wizard uploads the update file. A progress indicator shows the progress. When the upload is finished successfully and the instrument is idle, the **Restart Now** button is displayed. If the instrument is busy, the restart is postponed until the instrument is idle.

- 3 To restart immediately, select **Restart Now**.

The Assist Hub restarts with the installed update. The firmware updates thereafter.

Update Unsupported Firmware

If you connect an instrument with an unsupported firmware version to the Assist Hub, the **Status** screen does not display the status cards. Instead, it shows which modules have firmware that is not supported.

To ensure compatibility with the Assist Hub and other external controller connections (such as Chromatography Data Systems), the LC module firmware must be updated to the required minimum version. If the firmware is not updated, system incompatibilities may occur.

To update the firmware:

- 1 Select **Update Firmware** at the bottom right of the **Status** screen.

The current firmware versions are displayed, as well as the versions they will be updated to.

- 2 To start the update process, select **Yes**.



4 Using the Module

This chapter provides information on how to use the module.

General Information 41

Turn On/Off 41

Status Indicators 44

Using the Drivers with this Module 46

Launching the Browser User Interface 48

Using the InfinityLab Assist Interface 49

General Information

Turn On/Off

This procedure exemplarily shows an arbitrary LC stack configuration.

1

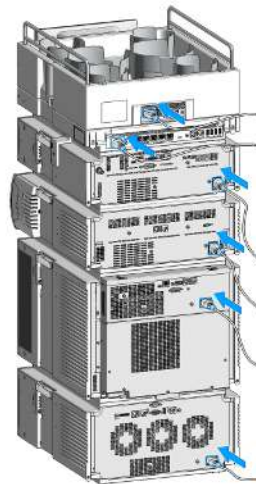

Using the Module

General Information

2 On/Off switch: On

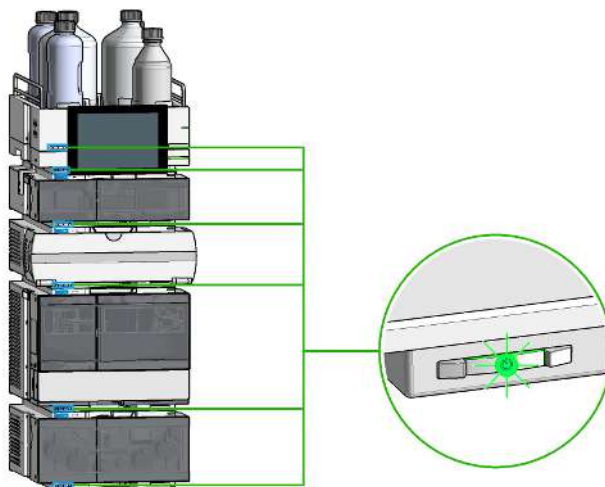

3 Turn instrument On/Off with the control software.

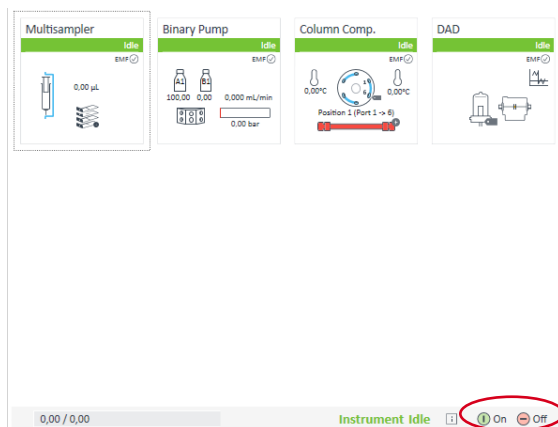

Using the Module

General Information

4 On/Off switch: Off

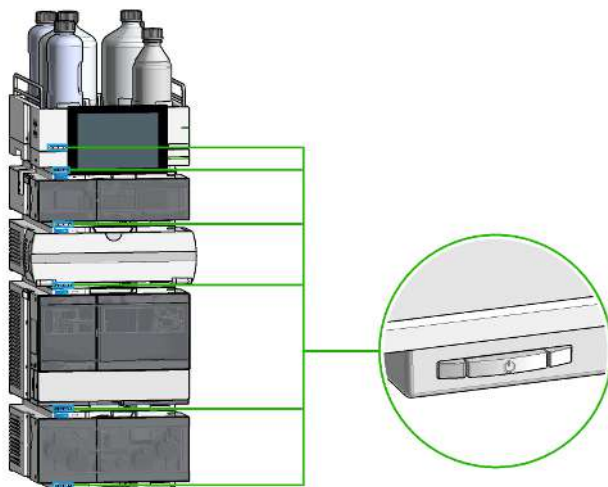

5

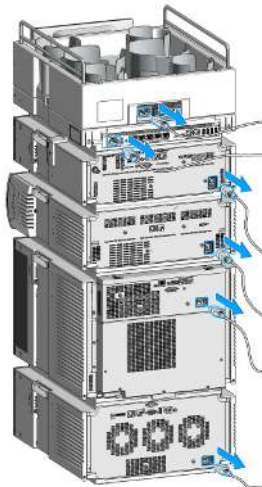

Status Indicators

The module status indicator indicates one of six possible module conditions.

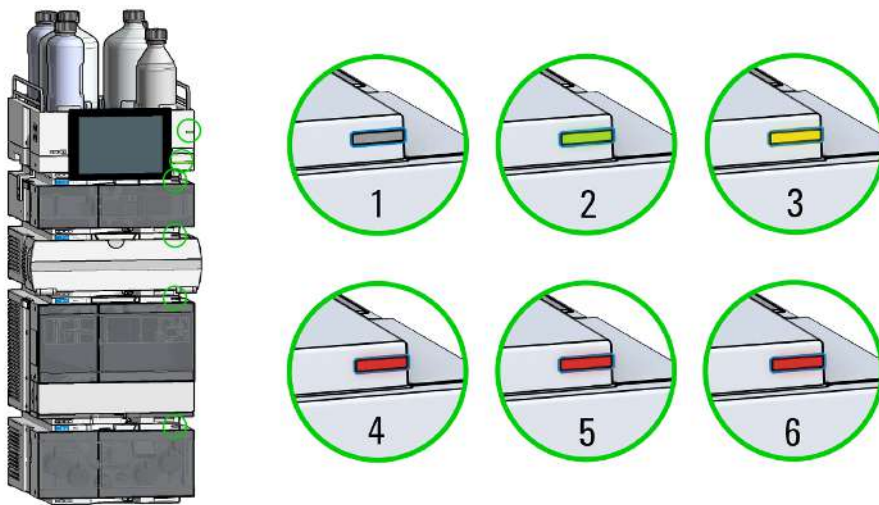

Figure 6: Arbitrary LC stack configuration (example)

1	Idle
2	Run mode
3	Not-ready. Waiting for a specific pre-run condition to be reached or completed.
4	Error mode - interrupts the analysis and requires attention (for example, a leak or defective internal components).
5	Resident mode (blinking) - for example, during update of main firmware.
6	Bootloader mode (fast blinking). Try to re-boot the module or try a cold-start. Then try a firmware update.

InfinityLab Assist Hub Status Indicator

The Assist Hub status indicator displays the status of the entire system. If a module in the system is not ready (yellow), the Assist Hub status indicator also shows not ready (yellow). The same applies for the module conditions **Idle**, **Run mode**, and **Error mode**.

InfinityLab Assist Interface and Assist Control Software Status Indicator

The status indicators of the Agilent InfinityLab Assist Interface and Assist Control Software have the same color as in the LC Driver.

Using the Drivers with this Module

If you are using LC & CE Driver version 3.7 or below, the Assist Hub will not have a driver tile in the CDS (Instrument Status Dashboard). Despite this, the Assist Hub can be used.

If you are using LC & CE Drivers with version 3.8 or above, a driver tile for the Assist Hub is displayed in the CDS (Instrument Status Dashboard).

Instrument Status

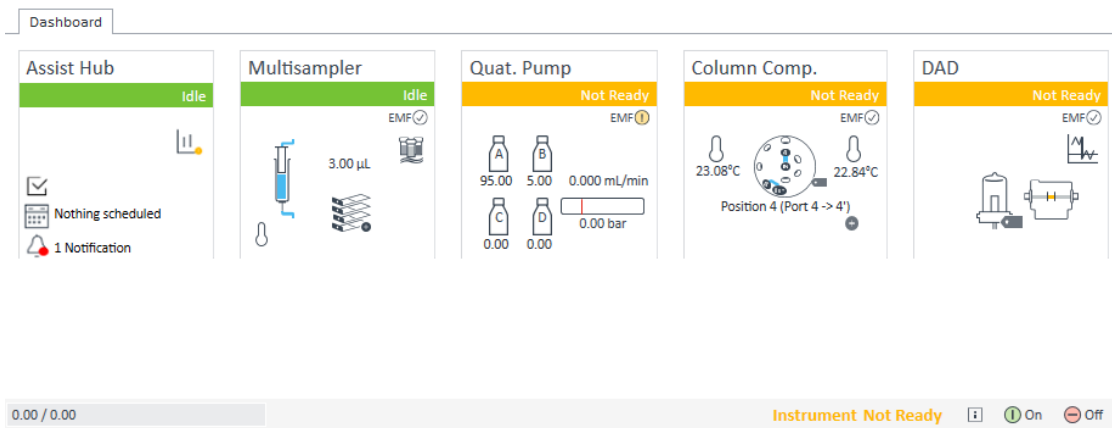

Figure 7: Dashboard of the CDS

Legend Assist Hub in the Instrument Status Dashboard



Displays the status of the EMF counters and instrument trends.

- If a check mark appears next to the graphic, then no maintenance is needed.
- If an orange dot appears next to the graphic, then maintenance is required. The tooltip shows which EMF counter or instrument trend requires attention.



Indicates whether a task is running. If a task is running, its name is displayed.

Using the Module

Using the Drivers with this Module



Indicates whether tasks are scheduled. If tasks are scheduled, the execution time and the name of the next scheduled task are displayed.



Indicates whether errors, warnings or other information are pending.

Launching the Browser User Interface

Preparations

- The PC or mobile device is in the same subnet as the Assist Hub.
- You are using a Chromium-based browser (Chrome, Edge, etc.) with a version higher 124.
- You are using a Safari-based browser with version higher 17.5.1.
- LC & CE Drivers with version 3.8 or above are installed.

- 1 In the CDS, navigate to the Instrument Status Dashboard.
- 2 Open the context menu of the Assist Hub tile (via right-click) and select **Open in browser...**

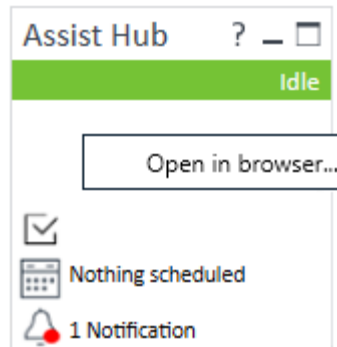

- ✓ The browser user interface of the Assist Control Software is launched directly from the CDS.

NOTE

On displays wider than 1280 pixels, the appearance of the browser's user interface differs from that of the Assist Interface.

For more information on remote access to the Assist Control Software via a web browser, refer to [Using the Assist Control Software Browser User Interface](#) on page 52.

Using the InfinityLab Assist Interface



WARNING

Risk of injury due to extended positioning of the holder in stand-by mode

If the arm of the holder is extended, there is a risk of catching on the InfinityLab Assist Interface. People passing by can get injured and the InfinityLab Assist Interface or other parts of the stack can be damaged. Solvent bottles in the solvent cabinet or the InfinityLab Level Sensing module above the InfinityLab Assist Hub can fall down if they are exposed to mechanical shocks.

- After use, return the InfinityLab Assist Interface to the home position: Move the InfinityLab Assist Interface to the highest position against the solvent cabinet or InfinityLab Level Sensing module.
-



5 Using the Software

Using the Assist Control Software Browser User Interface 52

Login and Logout 54

Log In 54

Log Out 56

Logout After Inactivity 56

Dark Screen After Inactivity (Assist Interface only) 56

User Interface Overview 57

Screen Elements 57

How to Work with the Software 62

Designing the Ambient Screen 62

Designing the Home Screen 64

Displaying the State of the Modules 67

Using Quick Actions 70

Creating Tasks 72

Setting Up a Service Block 87

Viewing Notifications 90

Setting Up the IP Address 91

About InfinityLab Assist Control Software 93

Versioning & Updates 94

Using the Assist Control Software Browser User Interface

InfinityLab Assist Control Software provides a user interface that runs on the Assist Interface. InfinityLab Assist Control Software can also be accessed remotely in Web browsers.

NOTE

On displays wider than 1280 pixels, the appearance of the browser's user interface differs from that of the Assist Interface.

Accessing the InfinityLab Control Software with a Web Browser

Access the browser user interface using the CDS (via the dashboard tile) or manually by entering the address in the web browser.

Preparations

- The PC or mobile device is in the same subnet as the Assist Hub.
- You are using a Chromium-based browser (Chrome, Edge, etc.) with a version higher 132.
- You are using a Safari-based browser with version higher 17.5.1.
- LC & CE Drivers with version 3.8 or above are installed.

Using the Software

Using the Assist Control Software Browser User Interface

Accessing the Browser User Interface via the CDS

- 1 In the CDS, navigate to the Instrument Status Dashboard.
- 2 Open the context menu of the Assist Hub tile (via right-click) and select **Open in browser...**

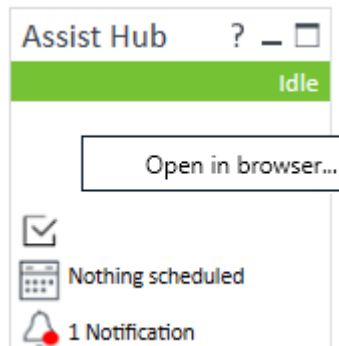

- ✓ The browser user interface of the Assist Control Software is launched.

Accessing the Browser User Interface via the Address Bar of the Web Browser

- 1 On the PC or mobile device, open your browser.
 - 2 In the address bar, enter the IP Address of the Assist Hub (<http://<IP address>>) or the MAC address with domain (<http://<macaddress>.<fully qualified domain>>). The device information, such as the MAC address, can be found on the Assist Hub label.
- ✓ The browser user interface of the Assist Control Software is launched.

Login and Logout

Log In

Prerequisites

- The Ambient screen is displayed.

Log In If Role-Based Authentication Is Active

- 1 Select  **Unlock** on the **Ambient** screen.
The login screen is displayed.
 - 2 Select a role.
 - 3 If the role is PIN-protected, enter the role-specific PIN.
- ✓ You are logged in with the permissions of the role.

Log In If OpenLab Authentication Is Active

- 1 Select  **Unlock** on the **Ambient** screen.
The login screen is displayed.
 - 2 Enter your OpenLab user name and password. If required, select the domain.
- ✓ You are logged in with the privileges of the OpenLab user account.



NOTE

Even if the OpenLab server is offline after OpenLab authentication has been established, InfinityLab Assist will still grant access to any OpenLab user accounts it recognizes from previous logins.

Log In If Authentication Is Off

- 1 Select  **Unlock** on the **Ambient** screen.
- ✓ You have full access to InfinityLab Assist and all its permissions.

Log Out

- 1 Select  from the main toolbar.
 - 2 Select  Log Out.
- ✓ The **Ambient** screen is displayed.

Logout After Inactivity

Users are automatically logged out after they have been inactive for the time period specified in the **Security** settings.

If a user logs in again with the same role on the same client, the previous session is continued. However, this will not work if another role has logged in to the same client in the meantime.

Dark Screen After Inactivity (Assist Interface only)

The Assist Interface dims the screen after users have been inactive for the time period specified in the **Assist Interface** settings.



- 1 To use the Assist Interface, touch the dark screen.

User Interface Overview

Screen Elements

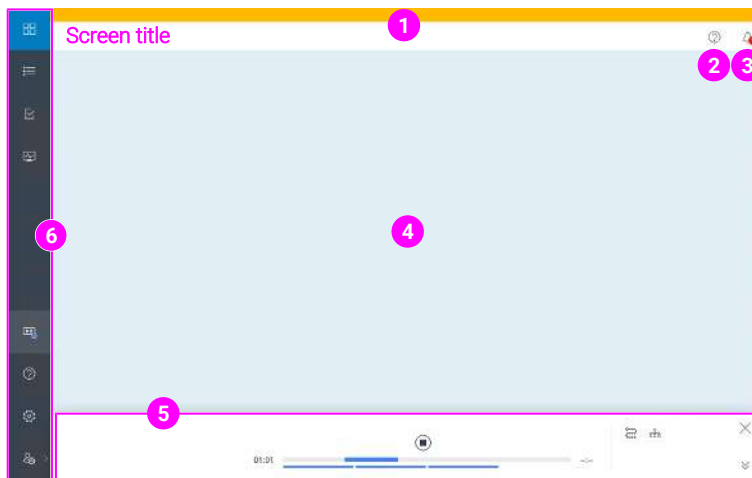
When you are logged in, InfinityLab Assist always displays the following screen elements:



Screen Element	Description
1 Overall status	The status bar is color-coded to indicate the overall status of the instrument. On displays wider than 1280 pixels, the status bar is located on the left side of InfinityLab Assist.
2 Screen help	To display information about the current screen, select  in the top toolbar.
3 Notifications	To display error messages, warnings, and information, select  in the top toolbar. If there are new or unconfirmed notifications, a red dot shows the amount. Module-specific status information is indicated on the Status screen. In addition, when a notification is received, a pop-up appears in the top right of InfinityLab Assist for five seconds (but not on the Ambient screen). If multiple notifications are received, the popup will only show the most recent notification.
4 Primary area	The primary area displays the content of the selected screen.

Using the Software





User Interface Overview

Screen Element	Description
5	Run Control panel The Run Control panel shows the progress of running tasks, procedures, or sequences. If applicable, you can pause or stop the execution. To open or close the Run Control panel, select  from the main toolbar.
6	Main toolbar The main toolbar gives you access to the different screens. On displays wider than 1280 pixels, the main toolbar is located at the top of InfinityLab Assist.

Main Toolbar



The main toolbar of InfinityLab Assist gives you access to the main screens.

On displays smaller than or equal to 1280 pixels, the main toolbar is located on the left side of InfinityLab Assist. On displays wider than 1280 pixels, the main toolbar is located at the top of InfinityLab Assist.

Tool	Description
	Displays the Home screen , which shows a status overview. Each user role can create an individual Home screen . You can add, remove, or rearrange the tiles.
	Displays the Status screen , which shows the status of each module on individual status cards and gives you access to quick actions. To display all the details of a module, select → in the title bar of the status card. The Status details screen gives you access to all available actions.
	Displays the Tasks screen , which lists the existing tasks and allows you to create, copy, or delete tasks. To display all the details of a task, select the task. The Task details screen allows you to execute, edit, or schedule the task.
	Displays the Health screen , which gives you access to: <ul style="list-style-type: none"> • Maintenance: Guided maintenance and tools for common tasks • Diagnostics: Diagnostics tests and wizards • Insights: EMF counters and statistics about the instrument • Block for Service: Block the instrument or schedule a block • Troubleshooting: Guided troubleshooting and information about pending problems • Log: Log of all activities being executed, sent, or received by the Assist Control Software (not available to Viewer role)
	Opens or closes the Run Control panel , which shows the progress of running tasks, procedures, or sequences. If applicable, you can pause or stop the execution. A blue dot indicates that a task, procedure, or sequence is running. A yellow dot indicates that manual interaction is required, such as opening or closing the purge valve.









Using the Software

User Interface Overview

Tool	Description
	Displays the online help.
	Displays the Settings screen , which shows the configuration and allows you to set up and configure the system.
	Allows you to log out. The tooltip shows the role that is logged in.

Assist Control Software Status Color Coding

The status bar at the top of InfinityLab Assist is color-coded according to the overall status of the instrument. On displays wider than 1280 pixels, the status bar is located on the left side of InfinityLab Assist.

Status	Description
 Offline	The connection to the instrument is lost (all modules switched off or LAN connection disconnected, for example), or an unsupported module or firmware is present in the LC system.
 Idle	The instrument is on and ready to process samples.
 Not Ready	The instrument is connected but is not ready to run (due to not reaching the correct temperature or pressure required by the method, for example).
 Error	The instrument has an error and cannot process samples.
 Standby	The instrument is in a standby/sleep state.
 Pre-Run	The instrument is on and is preparing to start acquisition.
 Injecting	Data acquisition is ongoing.
 Run or Post-Run	The instrument is collecting data.

Run Control Panel

Path:  Run Control

The Run Control panel shows the progress of running tasks, procedures, acquisition sequences, or single runs/injections.

To open or close the Run Control panel, select  from the main toolbar. A blue dot indicates that a task, procedure, or application is running.

If an application is running, the Run Control panel shows the name of the application, the progress bar, and lets you access the queue.

If the instrument is not being used, the Run Control panel indicates that nothing is running.

NOTE

A yellow dot to the left of the application name indicates that manual interaction is required, such as opening or closing the purge valve. If there is enough space to the right of the application name, the note **Interaction Required** appears instead of the yellow dot.

The yellow dot is also displayed on the menu item .

Progress Bar

The layout of the progress bar depends on the application.



- | | |
|---|---|
| 1 | The following tools can be available. |
| |  Aborts the application after you confirm.
Methods and sequences cannot be aborted via the Assist Control Software. |
| 2 | The remaining duration, if applicable |
| 3 | The indeterminate progress bar shows that the application is running. |

4	<p>The second progress bar is only displayed for tasks or procedures with multiple steps, or sequences with multiple runs. The progress bar is divided into steps or runs, the executed steps or runs are colored blue. The following information is displayed to the left of the progress bar:</p> <ul style="list-style-type: none"> • The name of the step (if available), the number of steps, and the number of steps executed • The number of runs and the number of runs executed
5	The elapsed time, in minutes and seconds, since the start of the application



Minimized View

The minimized view of the Run Control panel only shows the name of the application and a simple progress bar or that nothing is running.

To minimize the Run Control panel, select ☰. To expand it again, select ⤴.

Tools

The Run Control panel contains the following tools:

Tool	Description
	<p>Displays the Queue panel. It shows the tasks and procedures that have been completed or are currently being carried out and their status. It also shows the tasks and procedures that are waiting to be executed or are planned for today and the near future.</p> <p>To show details and results, select the item. For example, if you select a planned task, the Schedule tab of the task is displayed, which allows you to change or delete the schedule.</p>
	<p>Displays the CDS Required settings.</p> <p>A green dot indicates that a CDS is connected. A gray dot indicates that no CDS is required and no CDS is connected. A red dot indicates that a CDS is required but not connected.</p>

How to Work with the Software

Designing the Ambient Screen

The **Ambient** screen is displayed when InfinityLab Assist is locked. It displays live data without the need of unlocking InfinityLab Assist.

The **Ambient** screen displays the overall status of the instrument, the instrument name and location, and a variety of widgets. The widgets show, for example, online plots or status indicators.







For details on the instrument status, see [Assist Control Software Status Color Coding](#) on page 59.

Changing the Layout of the Ambient Screen

Prerequisites

- To change the layout, you need the permission **Edit ambient screen layout**. The roles **Agilent Service Technician** or **Administrator** have the permission by default.

- 1 On the **Ambient** screen, select  **Edit Screen**.
- 2 Login with your user credentials.
- 3 To add, remove, or rearrange the widgets, select the desired option:

Tool	Description
	Allows you to rearrange the widgets. Drag the grabber and drop the widget at the new position.
	Opens the widget catalog, which allows you to change the widget's size or replace it.
	Deletes the widget.
 Default Layout	Resets the layout of the Ambient screen to the default layout. <ul style="list-style-type: none"> • Online Plot (large) with detector signals A and B • Flow • Pressure • Solvent Composition • Column Thermostat • Run Control (medium)
 Cancel	Discards the changes and exits the edit mode.
 Save	Saves the changes and exits the edit mode.
 Add Widget	Opens the widget catalog, which allows you to add a tile.

For details on the available widgets, see [Widget Catalog](#) on page 66.

NOTE

After updating the Assist Control Software, some of the widgets may have been modified/updated. The administrator must confirm that the Ambient screen is still displaying the desired information.









Designing the Home Screen

Path:  Home

The **Home** screen displays a role-specific status overview. You can add, remove, or rearrange the tiles (widgets). If OpenLab authentication is active, the **Home** screen is user-specific.









Changing the Layout of the Home Screen

- 1 On the **Home** screen, select  **Edit Screen**.
- 2 To add, remove, or rearrange the widgets, select the desired option from the toolbar:

Tool	Description
	Opens the Home screen in edit mode.
	Allows you to rearrange the widgets. Drag the grabber and drop the tile at the new position.
	Opens the widget catalog, which allows you to change the widget's size or replace it.
	Deletes the widget.
 Default Layout	Resets the layout of the Home screen to the default layout. <ul style="list-style-type: none"> • Online Plot (large) with detector signals A and B • Flow • Pressure • Solvent Composition • Column Thermostat • Run Control (medium)
 Cancel	Discards the changes and exits the edit mode.
 Save	Saves the changes and exits the edit mode.
+ Add Widget	Opens the widget catalog, which allows you to add a widget.
	Displays the screen help.
	Displays errors, warnings, and other information.

Widget Catalog

The following widgets are available on the **Ambient** and **Home** screens:

Widget	Description
 Online Plot	The Online Plot widget displays the last 15 minutes of up to four signals. The size of the widget can be small, medium, or large. Only the large widget displays more than one signal at the same time. To toggle the signals in the small and medium widgets, drag the widget to the right or left.
 Pressure	The Pressure widget displays the current pressure in text and visual form. And it shows the module name. The visual display also shows the pressure limit.
 Flow	The Flow widget displays the current flow in text and visual form. It also displays the module name. If the flow is limited by pressure, the flow fill on the visual display is yellow with a warning triangle below.
 Solvent Composition	The Solvent Composition widget displays the current solvent composition in text and visual form. It also shows the module name.
 Sample Thermostat	The Sample Thermostat widget displays the current temperature of the sampler's thermostat in text and visual form. And it displays the module name. The visual display also shows the temperature setpoint. If the target temperature has been reached, the thermometer fill is green, otherwise it is blue. If the target temperature has not yet been reached, the widget indicates that the thermostat is heating or cooling.
 Column Thermostat	The Column Thermostat widget displays the current temperature of the column thermostat in text and visual form. And it displays the module name. The visual display also shows the temperature setpoint. If the target temperature has been reached or the temperature mode is Not Controlled , the thermometer fill is green, otherwise it is blue. If the target temperature has not yet been reached, the widget indicates that the thermostat is heating or cooling.
 Module Status	The Module Status widget shows the color-coded status of the instrument's functional groups: <ul style="list-style-type: none"> • Solvent Delivery (including Level Sensing, if configured) • Injection • Separation • Detection
 Run Control	The Run Control widget shows the progress of running tasks, procedures, acquisition sequences, or single runs/injections. The size of the widget can be small or medium. If the instrument is not being used, the Run Control widget indicates that nothing is running.

Displaying the State of the Modules

Path: ☰ **Status**

The **Status** screen shows the status of each module on individual status cards and gives you access to quick actions.

NOTE

If your instrument does not meet the minimum requirements, you cannot use InfinityLab Assist to control the instrument. Then the **Status** screen does not display the status cards, and instead suggests how to control the module.

For more details, refer to the InfinityLab Assist online help.

Structure of the Module Status Cards

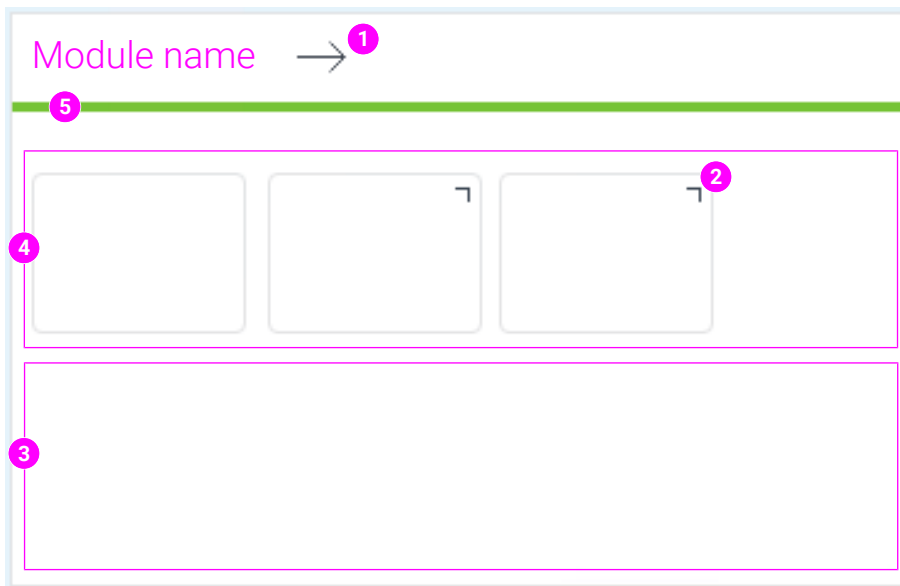

The screen shows a status card for each module of the instrument. The cards are structured as follows:



1	Module name →	Displays the module-specific Status details screen with all details and status messages.
2	Caret indicator	Indicates that a dialog box is displayed when you select the quick action.
3	Actuals	Shows visual displays and selected actuals.
4	Quick actions	Gives access to selected quick actions that you can use to control the instrument. For details, see Using Quick Actions on page 70. The order of the quick actions can be customized on the Status details screen of each module. If no quick actions are available, then the module card will show additional instrument actuals.
5	Module status	Displays the color-coded status of the module. For details, see Assist Control Software Status Color Coding on page 59.

Arranging Module Status Cards

The order of the module status cards shown on the **Status** screen can be customized as follows:

- 1 From the toolbar of the **Status** details screen, select .
- 2 Drag the grabber  and drop the module status card at the new position.
- 3 Save your changes.

Using Quick Actions

Path: ☰ Status

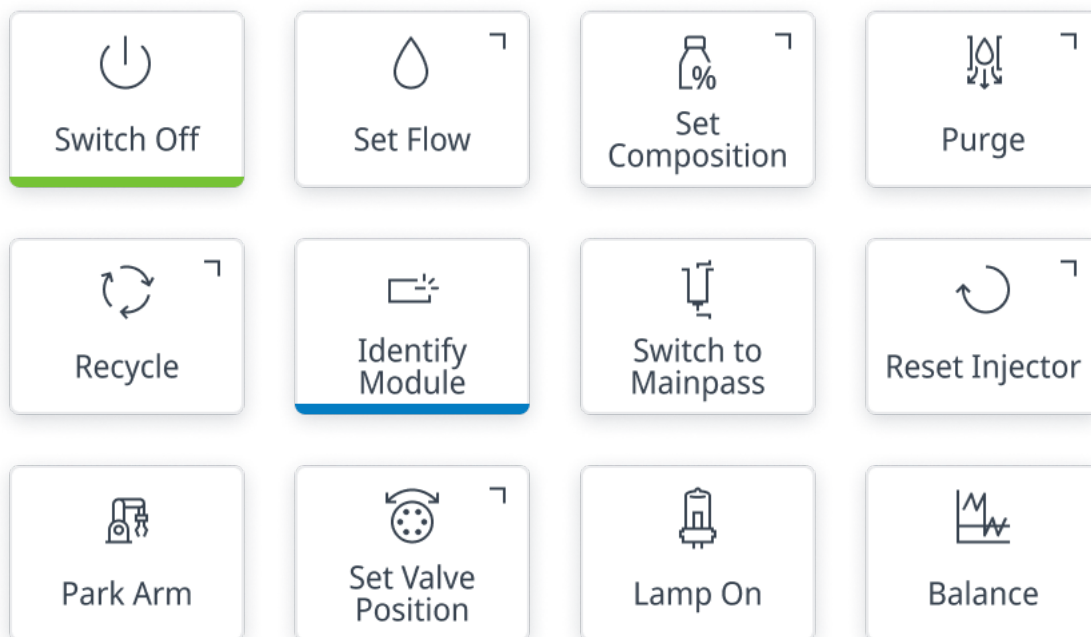

Use the quick actions on the **Status** screen to control the instrument and review its status.

Depending on the existing modules, the following quick actions are available:



Setting up the Position of Quick Actions

Each module has its own predefined quick actions. The order of the quick actions shown in the Module Status Card can be customized as follows.

- 1 From the **Status** screen, select **Module name** →.
 - 2 Select  to rearrange the quick actions.
 - 3 Drag the grabber  and drop the quick action at the new position.
- ✓ The first four quick actions on the left-hand side are displayed on the Module Status Card on the **Status** screen.

Creating Tasks

Path:  Tasks





You use tasks to automate recurring processes, such as preparing the instrument or putting it to sleep.

You create tasks using predefined task templates:

Template	Description
Make Ready	The task prepares the instrument for use. You can use it to switch on the modules, purge, and equilibrate the configured flow path. See Creating a Make Ready Task on page 75.
Standby	The task puts the instrument into sleep or into standby mode. You can use it to flush the column, fill the column, and switch off the column thermostat, the sample thermostat, and the lamp. See Creating a Standby Task on page 78.



Steps of the Make Ready Task

A Make Ready task may consist of the following four steps:

Step	Importance	Description
 Purge System	Optional	The step will be executed first. It uses a high flow rate and purges the chosen channels sequentially through the sampler needle tip into waste.
 Pre-Flush System	Optional	The step prepares the flow path with the specified composition.
 Gradient Flush System	Optional	The step prepares the flow path with the specified composition according to the gradient timetable.
 Equilibrate	Mandatory	The step is the final step of the Make Ready task. It ensures that the column and the system will be in an equilibrated state.

Steps of the Standby Task

A Standby task may consist of the following three steps:

Step	Importance	Description
 System Flush	Optional	The step will be executed first. It flushes the column and the system with the specified composition.
 Store Column	Optional	The step will be executed before the Standby step. It fills the column and the system with the specified storage composition.
 Standby	Mandatory	The step is the final step of the Standby task. It puts the system into sleep or into standby with reduced or no pump flow. It switches off the column thermostat, the sample thermostat, and the detector as specified.

The **Tasks** screen lists the existing tasks in alphanumeric order and allows you to create, edit, or execute tasks.

Required Permissions

- To configure tasks, you need the **Edit tasks** permission. The roles **Maintenance Technician**, **Agilent Service Technician**, or **Administrator** have this permission by default.
- To schedule tasks, you need the **Schedule tasks** permission. The roles **Maintenance Technician**, **Agilent Service Technician**, or **Administrator** have this permission by default.
- To run tasks interactively, you need the **Start tasks** permission. The roles **Lab Analyst**, **Maintenance Technician**, **Agilent Service Technician**, or **Administrator** have this permission by default.
- To abort tasks, you need the **Abort tasks** permission. The roles **Lab Analyst**, **Maintenance Technician**, **Agilent Service Technician**, or **Administrator** have this permission by default.

Searching for Specific Tasks

- 1 From the task list toolbar, select  to filter the list by **Make Ready** or **Standby** tasks.

If you apply the filter criteria, the icon shows the number of chosen filter criteria.

- ✓ Only tasks that meet at least one of the chosen filter criteria are displayed and other tasks are hidden.

OR

Select the search field  and enter a string to search through all entries in the list. If you apply filter criteria at the same time, the search only takes place in the filter results.

- ✓ The search looks in all entries within the task list and displays the matches.

Creating a Make Ready Task

Prerequisites

- To be able to carry out the procedure as described you need the permission **Edit tasks**. The roles **Maintenance Technician**, **Agilent Service Technician**, or **Administrator** have the permission by default.

NOTE



Modules that are part of a cluster must not be configured in a **Make Ready** task. Otherwise, the task is invalid and cannot be started.

Starting with LC/CE Drivers version 3.11, the HDR-DAD Cluster and Valve Thermostat Cluster (VTC) are available for **Make Ready** tasks.

Create Task



- Select  from the main toolbar.
The **Tasks** screen is displayed.
- Select **Create Task**.
The predefined task templates are displayed.
- Select the **Make Ready** task template and confirm with **Select**.
The default task name and description are displayed.
- Change the task name.
You can also change the description.
- Select **Create Task**.
The system creates the task and adds it to the task list.
The **Overview** tab of the **Make Ready** task is displayed.

Adjust Equilibration Settings





- On the **Overview** tab of the **Make Ready** task, select  **Equilibrate**.
The **Equilibrate** screen is displayed.
- Adjust the Equilibration settings. Select  to access the online help for more details.

Using the Software



How to Work with the Software

- 3 Select  in the top toolbar.
The **Make Ready** task is saved.
- 4 Select  in the title bar.
The **Overview** tab of the **Make Ready** task is displayed.
- 5 You can add optional steps if necessary, run, or schedule the **Make Ready** task.

Add Purge System Step (Optional)



- 1 On the **Overview** tab of the **Make Ready** task, select  **Purge System**.
- 2 The **Purge System** step is added to the **Make Ready** task.
- 3 Select  **Purge System** again.
The **Purge System** screen is displayed.
- 4 Adjust the Purge settings. Select  to access the online help for more details.
- 5 Select  in the top toolbar.
The **Make Ready** task is saved.
- 6 Select  in the title bar.
The **Overview** tab of the **Make Ready** task is displayed.

Add Pre-Flush System Step (Optional)





- 1 On the **Overview** tab of the **Make Ready** task, select  **Pre-Flush System**.
- 2 The **Pre-Flush System** step is added to the **Make Ready** task.
- 3 Select  **Pre-Flush System** again.
The **Pre-Flush System** screen is displayed.
- 4 Adjust the Pre-Flush System settings. Select  to access the online help for more details.

Using the Software

How to Work with the Software

- 5 Select  in the top toolbar.
The **Make Ready** task is saved.
- 6 Select  in the title bar.
The **Overview** tab of the **Make Ready** task is displayed.

Add Gradient Flush System Step (Optional)

- 1 On the **Overview** tab of the **Make Ready** task, select  **Gradient Flush System**.
- 2 The **Gradient Flush System** step is added to the **Make Ready** task.
- 3 Select  **Gradient Flush System** again.
The **Gradient Flush System** screen is displayed.
- 4 Adjust the settings. Select  to access the online help for more details.
- 5 Select  in the top toolbar.
The **Make Ready** task is saved.
- 6 Select  in the title bar.
The **Overview** tab of the **Make Ready** task is displayed.

Creating a Standby Task

Prerequisites

- To be able to carry out the procedure as described you need the permission **Edit tasks**. The roles **Maintenance Technician**, **Agilent Service Technician**, or **Administrator** have the permission by default.

NOTE



Modules that are part of a cluster must not be configured in a **Standby** task. Otherwise, the task is invalid and cannot be started.

Starting with LC/CE Drivers version 3.11, the HDR-DAD Cluster and Valve Thermostat Cluster (VTC) are available for **Standby** tasks.

Create Task



- 1 Select  from the main toolbar.
The **Tasks** screen is displayed.
- 2 Select **Create Task**.
The predefined task templates are displayed.
- 3 Select the **Standby** task template and confirm with **Select**.
The default task name and description are displayed.
- 4 Change the task name.
You can also change the description.
- 5 Select **Create Task**.
The system creates the task and adds it to the task list.
The **Overview** tab of the **Standby** task is displayed.

Adjust Standby Settings





- 1 On the **Overview** tab of the **Standby** task, select  **Standby**.
The **Standby** screen is displayed.
- 2 Adjust the Standby settings. Select  to access the online help for more details.

Using the Software



How to Work with the Software

- 3 Select  in the top toolbar.
The **Standby** task is saved.
- 4 Select  in the title bar.
The **Overview** tab of the **Standby** task is displayed.
- 5 You can add optional steps if necessary, run, or schedule the **Standby** task.

Add System Flush Step (Optional)



- 1 On the **Overview** tab of the **Standby** task, select  **System Flush**.
- 2 The **System Flush** step is added to the **Standby** task.
- 3 Select  **System Flush** again.
The **System Flush** screen is displayed.
- 4 Adjust the System Flush settings. Select  to access the online help for more details.
- 5 Select  in the top toolbar.
The **Standby** task is saved.
- 6 Select  in the title bar.
The **Overview** tab of the **Standby** task is displayed.

Add Store Column Step (Optional)

- 1 On the **Overview** tab of the **Standby** task, select  **Store Column**.
- 2 The **Store Column** step is added to the **Standby** task.
- 3 Select  **Store Column** again.
The **Store Column** screen is displayed.
- 4 Adjust the Store Column settings. Select  to access the online help for more details.

Using the Software

How to Work with the Software







- 5 Select  in the top toolbar.
The **Standby** task is saved.
- 6 Select  in the title bar.
The **Overview** tab of the **Standby** task is displayed.

Editing a Task

Prerequisites

- To be able to carry out the procedure as described you need the permission **Edit tasks**. The roles **Maintenance Technician**, **Agilent Service Technician**, or **Administrator** have the permission by default.

- 1 Select the task on the **Task** screen.
- 2 In the top toolbar of the Task Details Screen, you have the following editing options:

Tool	Description
	Saves the changes. The tool is disabled when no changes were made since the last save.
	Run Task Executes the task. If the instrument is busy, the task is queued.
	Edit Displays a dialog box where you can change the name and description of the task.
	Duplicate Displays a dialog box where you must enter a unique name for the duplicate.
	Delete Deletes the task after you confirm.
	Displays the screen help.
	Displays errors, warnings, and other information.

- 3 To edit a step of the task, select the desired step on the **Overview** tab of the Task Details Screen. Select  to access the online help for more details.

For information on the available steps, see [Steps of the Make Ready Task](#) on page 72 or [Steps of the Standby Task](#) on page 73.

Resolving a Task

A task that needs to be resolved is indicated with a yellow triangle and exclamation mark  in the tasks list. Invalid tasks cannot be executed.

A task may become invalid if it has been imported, or if the system configuration has changed.

Prerequisites

- To be able to carry out the procedure as described you need the permission **Edit tasks**. The roles **Maintenance Technician**, **Agilent Service Technician**, or **Administrator** have the permission by default.

- 1 In the **Tasks** screen, select the task that needs to be resolved.
- 2 In the **Overview**, the reason why the task requires resolution is displayed in yellow. The step of the task that requires resolution (for example, Equilibration) is displayed in red.
- 3 Correct all red steps of the task and edit the correct configuration and information.
- 4 **Save** the task.

Executing a Task

- 1 Select the task on the **Task** screen.
 - 2 To execute the task, select **Run Task** on the **Overview** tab.
- ✓ Before executing a task, task management checks if there are any facts that will lead to invalid results. If so, task management generates an error message and does not execute the task. Error messages and warnings are displayed as notification  in the top toolbar.

Scheduling a Task

The **Schedule** tab of the Task Details Screen shows the existing schedules of the task and allows you to create, edit, or delete schedules.



Use the task scheduler to run tasks automatically on specified times or intervals. Use intervals to trigger periodic maintenance, for example.

- 1 Select the task on the **Task** screen.
 - 2 Select the **Schedule** tab.
 - 3 Select **Create Schedule** to schedule the task.
The **Create Schedule** dialog box opens.
 - 4 Enter the data for the schedule. Select  to access the online help for more details.
 - 5 Select **Create Schedule** to save your settings.
- ✓ The scheduled task is displayed on the **Schedule** tab of the Task Details Screen and in the **Schedule** section of the **Task** screen.

Editing a Schedule

The **Schedule** section on the **Task** screen shows the tasks that have already been completed and those planned for today and the near future.



To Change the Schedule Settings:

- 1 In the **Schedule** section, select  for the schedule whose settings you want to change.
 - 2 Select **Configure Schedule**.
The **Schedule** tab of the Task Details Screen opens.
 - 3 Select  for the schedule whose settings you want to change.
The **Edit Schedule** dialog box opens.
 - 4 Enter the data for the schedule. Select  to access the online help for more details.
 - 5 Save your settings.
- ✓ The scheduled task is displayed on the **Schedule** tab of the Task Details Screen and in the **Schedule** section of the **Task** screen.

To Skip the Schedule:

- 1 In the **Schedule** section, select  for the schedule whose settings you want to change.
 - 2 Select **Skip this Occurrence**.
- ✓ The schedule has now the status **Will be Skipped**.

To Delete a Schedule:

- 1** In the **Schedule** section, select  for the schedule whose settings you want to change.
 - 2** Select **Configure Schedule**.
The **Schedule** tab of the Task Details Screen opens.
 - 3** Select  for the schedule you want to delete.
The **Edit Schedule** dialog box opens.
 - 4** Select **Delete** and confirm with **OK**.
- ✓ The schedule will be removed from the list.

Viewing the Task Execution History



- 1 Select the task on the **Task** screen.
- 2 Select the **Results** tab on the Task Details Screen.
The **Execution History** is displayed.
- 3 To view details of the individual entries, select → in the **Details** column.

Setting Up a Service Block

Blocking the Instrument for Service

The **Block Instrument for Service** dialog box allows you to block the instrument.

Prerequisites

- To block the instrument for service, you need the permission **Activate/deactivate service mode**. The roles **Maintenance Technician**, **Agilent Service Technician**, or **Administrator** have the permission by default.
- 1 Navigate to  **Health** >  **Block for Service**
 - 2 Select **Block Now**.
 - 3 In the **Block Instrument for Service** dialog, enter a title (mandatory). It will be displayed in the block banner and in related notifications.
 - 4 Select **Block Instrument**.
- ✓ The instrument is blocked. The button will change to **Unblock**.
 - ✓ If the instrument is busy, the block is pending until the instrument is idle.

Effects of Blocking the Instrument

The block has the following effect:

- Chromatography Data Systems (CDS) with LC/CE Drivers version 3.10 or above are disconnected. If a CDS with LC/CE Drivers version 3.10 or above tries to connect or reconnect, a connection error is generated.
- The **Instrument Blocked for Service** banner is displayed below the status bar on all screens in all sessions while the block is in place. It contains a link to view the **Block for Service** screen.
- Users without the permission **Activate/deactivate service mode** cannot do the following:
 - Execute quick actions.
 - Start tasks.
 - Execute maintenance, diagnostic, or troubleshooting procedures.
 - Upload and install new versions of the Assist Control Software and module-specific firmware.
 - Modify security settings.
 - Export or import settings.
 - Create or restore backups.
- Scheduled tasks that become active are immediately skipped.

To Remove a Block

- 1 Select **Unblock** on the **Block for Service** screen.

OR

Select **Unblock** in the **Instrument Blocked For Service** notification.



- ✓ The block is removed.

Scheduling a Block for Service

The **Schedule Block for Service** dialog box allows you to create a schedule for the block.

Prerequisites

- To schedule a block for service, you need the permission **Activate/deactivate service mode**. The roles **Maintenance Technician**, **Agilent Service Technician**, or **Administrator** have the permission by default.

- 1 Navigate to  Health >  Block for Service
 - 2 Select **Create Schedule**.
 - 3 In the **Schedule Block for Service** dialog, enter a title (mandatory). It will be displayed on the **Schedule Block for Service** screen, in the block banner and in related notifications.
 - 4 Enter a **Date** and **Time** (system time) of the day when the block will be executed.
 - 5 Save your settings.
- ✓ The schedule is shown in the list of schedules on the **Block for Service** screen.
 - ✓ As the scheduled block approaches, the **Approaching Scheduled Service** notification is generated (1 month, 2 weeks, 1 week, 3 days, 1 day, and 5 minutes in advance).

To Delete a Schedule

- 1 Select the schedule from the **Block for Service** screen.
 - 2 In the **Schedule Block for Service** dialog, select **Delete**.
- ✓ The schedule is removed from the list of schedules on the **Block for Service** screen.

Viewing Notifications

The **Notifications** panel displays error messages, warnings, and other information. The panel supports troubleshooting with various quick actions. Notifications are documented in the **Log**.

Error messages	The error messages are created when a failure occurs that requires attention before the analysis can be continued. When an error has been fixed, the notification disappears.
Warnings	The warnings are created in the following cases, for example: <ul style="list-style-type: none"> • An EMF counter exceeds 80% of the limit • An EMF counter exceeds the limit • The power button of a module has been switched off • The seal wash sensor of the pump has an error
Information	Information is created when, for example, a software or firmware update is available or has been installed.

When a notification is received, a pop-up appears in the top right of InfinityLab Assist for five seconds (but not on the Ambient screen). If multiple notifications are received, the pop-up will only show the most recent notification.

To open the **Notifications** panel, select  in the top toolbar. If there are new or unconfirmed notifications, a red dot shows the amount.

To access quick actions for a notification, select the notification.

To delete all notifications, select **Clear All** at the bottom of the **Notifications** panel. If a notification cannot be deleted because the cause is still present, you will be notified.

Setting Up the IP Address

You can change the default IP configuration for the Lab LAN interface of the InfinityLab Assist Hub. Lab LAN is reserved for the system connection to the PC or laboratory LAN infrastructure.

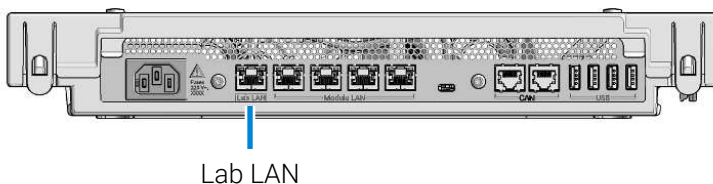

Figure 8: Assist Lab LAN interface on the back of the InfinityLab Assist Hub

Preparations

- The configuration switch on the left side of the Assist Hub must be in the front (right) position. For details on the configuration switch, see [Table Connections Assist Hub](#) on page 147.
- To configure the connection settings, you need the permission **Configure network connection**. The roles **Maintenance Technician**, **Agilent Service Technician**, or **Administrator** have this permission by default.

NOTE

Select the connection settings carefully. The default IP configuration may cause network problems in your local area network.

Using the Software

How to Work with the Software

- 1 Log in to the Assist Control Software.
- 2 Under  **Settings** > **Instrument** > **Connection Settings**, configure the IP address.

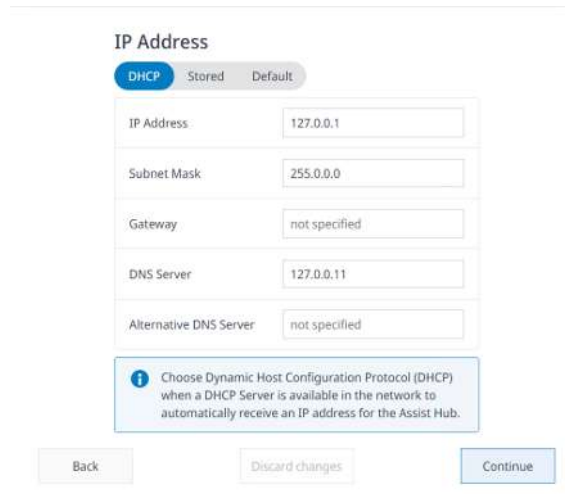

- ✓ You can choose between **DHCP**, **Stored**, or **Default**.

Parameter	Description
DHCP <input type="radio"/> Stored <input type="radio"/> Default <input checked="" type="radio"/>	DHCP requires a DHCP server in your network. The DHCP server assigns the IP configuration automatically. The IP configuration is displayed (if assigned).
DHCP <input type="radio"/> Stored <input checked="" type="radio"/> Default <input type="radio"/>	Stored allows you to specify the IP configuration. IP Address and Subnet Mask are mandatory. Gateway , DNS Server , and Alternative DNS Server are optional. If the option Allow Multiple IP Addresses is enabled, you can assign two different IP addresses. The two IP addresses must be on the same network.
DHCP <input type="radio"/> Stored <input type="radio"/> Default <input checked="" type="radio"/>	Default sets the default IP configuration. You cannot change it. The default IP configuration: <ul style="list-style-type: none"> • IP Address: 192.168.254.11 • Subnet Mask: 255.255.255.0 • Gateway: not specified • DNS Server: not specified • Alternative DNS Server: not specified

Select  to access the online help for more details.

About InfinityLab Assist Control Software

Path:  **Settings** > **About**

The **About** tab on the **Settings** screen provides the following information:

- End-user license agreement (EULA)
- Open-source components
- Assist Control Software version: The screen shows what's new in the Assist Control Software and module-specific firmware. Use the toggle function to filter only for HW configurations that apply to the modules in your instrument. For more information on versioning, see [Versioning & Updates](#) on page 94.
- Agilent Improvement Program: Administrator can optionally select to participate or not to participate in the Agilent Improvement Program.
- The Onboarding Guide presents the most important features of InfinityLab Assist.

Versioning & Updates

The Assist Hub uses only a single software package, the Assist Control Software. No separate software or firmware is needed.

Due to technical limitations, the software version number is displayed in a firmware-style format in the LC Driver module information and in the Lab Advisor System Overview. When they show E.01.00 [0004], it is simply another way of showing version 1.0.4.

The following table summarizes the released Assist Control Software versions:

Table 9: Assist Control Software Versions

Marketing Version	Software Version	Firmware-Style Format
2.1	2.1.9	E.02.01 [0009]
2.0	2.0.14	E.02.00 [0014]
1.1	1.1.0	E.01.01 [0000]
1.0	1.0.4	E.01.00 [0004]



6 Configuring the Assist Control Software

For further configuration instructions, refer to the *Agilent InfinityLab Assist Administration Manual (InfinityLab-Assist-AdmMa-en-D0123783.pdf, D0123783)*. The manual covers the following topics:

- Language, date & time settings
- Export support files
- Backup and restore
- Import and export settings and tasks
- Instrument settings
- Security and compliance functions:
 - Authentication
 - Access tokens
 - CDS requirements
 - Secure access via HTTPS/TLS
- Advanced settings



7 Troubleshooting and Diagnostics

This chapter gives an overview of the maintenance, troubleshooting, and diagnostic features available.

Status Indicators 97

Block for Service 98

Instrument Blocked for Service Notification 98

Overview of Available Tests and Tools 99

Maintenance Procedures 99

Diagnostic Procedures 102

Maintenance and Troubleshooting Tools 104

Maintenance Procedures 104

Troubleshooting Tools 105

Status Indicators

The Agilent InfinityLab Series LC modules are equipped with two status indicator LED lights to enable the user to get an immediate visual impression of the actual state of the instrument:

- The power indicator light is integrated into the main switch of the module and provides information about whether the system is powered on. When the indicator illuminates in green, the module is on.
- The module status indicator light is in the upper right corner of the module and provides information on the actual operating state of the system, see [Status Indicators](#) on page 44 for more information.

Block for Service

The **Block for Service** screen indicates whether a block is active or scheduled. It allows you to block or unblock the instrument, or schedule blocks.

To block, unblock, or schedule a block, you need the permission **Activate/deactivate service mode**. The roles **Maintenance Technician**, **Agilent Service Technician**, or **Administrator** have this permission by default.

For information on how to work with service blocks, refer to **Blocking the Instrument for Service** on page 87 or **Scheduling a Block for Service** on page 89.

Instrument Blocked for Service Notification

The **Instrument Blocked For Service** notification is generated when the instrument has been blocked. The notification contains an **Unblock** button that you can use to remove the block.

NOTE

Before unblocking, ensure that the block is no longer required.

Overview of Available Tests and Tools

Maintenance Procedures

Table 10: Overview of tasks and related modules

Maintenance tasks	Modules
Log Capillary Exchange	<ul style="list-style-type: none"> • G7110B 1260 Isocratic Pump • G7111A/B 1260 Quaternary Pump VL/ 1260 Quaternary Pump • G7112B 1260 Binary Pump • G7104A/C 1290 Flexible Pump/ 1260 Flexible Pump • G7120A 1290 High-Speed Pump • G5654A 1260 Bio-inert Quaternary Pump • G7131A/C 1290 Bio Flexible Pump/ 1260 Bio Flexible Pump • G7132A 1290 Bio High-Speed Pump
Exchange Purge Valve Frit or Purge Valve	<ul style="list-style-type: none"> • G7110B 1260 Isocratic Pump • G7111A/B 1260 Quaternary Pump VL/ 1260 Quaternary Pump • G7112B 1260 Binary Pump • G5654A 1260 Bio-inert Quaternary Pump
Pump Head Maintenance	<ul style="list-style-type: none"> • G7110B 1260 Isocratic Pump • G7111A/B 1260 Quaternary Pump VL/ 1260 Quaternary Pump • G7112B 1260 Binary Pump • G5654A 1260 Bio-inert Quaternary Pump
Pump Head Maintenance (Infinity III Support Ring Design):	<ul style="list-style-type: none"> • G7110B 1260 Isocratic Pump • G7111A/B 1260 Quaternary Pump VL/ 1260 Quaternary Pump • G7112B 1260 Binary Pump
Long Life Pump Head Maintenance	<ul style="list-style-type: none"> • G7104A/C 1290 Flexible Pump/ 1260 Flexible Pump • G7120A 1290 High-Speed Pump • G7131A/C 1290 Bio Flexible Pump/ 1260 Bio Flexible Pump • G7132A 1290 Bio High-Speed Pump

Troubleshooting and Diagnostics

Overview of Available Tests and Tools

Maintenance tasks	Modules
Exchange Peristaltic Pump	<ul style="list-style-type: none"> • G7110B 1260 Isocratic Pump • G7111A/B 1260 Quaternary Pump VL/ 1260 Quaternary Pump • G7112B 1260 Binary Pump • G7104A/C 1290 Flexible Pump/ 1260 Flexible Pump • G7120A 1290 High-Speed Pump • G5654A 1260 Bio-inert Quaternary Pump • G7131A/C 1290 Bio Flexible Pump/ 1260 Bio Flexible Pump • G7132A 1290 Bio High-Speed Pump • G7129A/B/C 1260 Vialsampler/ 1290 Vialsampler • G7167A/B/C (Dual-Needle Supported) 1260 Multisampler/ 1290 Multisampler/ 1260 Hybrid Multisampler • G5668A 1260 Bio-inert Multisampler • G7137A/B 1290 Bio Multisampler/ 1290 Hybrid Multisampler
Replace High Pressure Outlet Filter or Filter Frit	<ul style="list-style-type: none"> • G7104A/C 1290 Flexible Pump/ 1260 Flexible Pump • G7131A/C 1290 Bio Flexible Pump/ 1260 Bio Flexible Pump
Exchange Needle and Seat	<ul style="list-style-type: none"> • G7129A/B/C 1260 Vialsampler/ 1290 Vialsampler • G7167A/B/C (Dual-Needle Supported) 1260 Multisampler/ 1290 Multisampler/ 1260 Hybrid Multisampler • G5668A 1260 Bio-inert Multisampler • G7137A/B 1290 Bio Multisampler/ 1290 Hybrid Multisampler
Exchange Metering Seal and Piston	<ul style="list-style-type: none"> • G7129A/B/C 1260 Vialsampler/ 1290 Vialsampler • G7167A/B/C (Dual-Needle Supported) 1260 Multisampler/ 1290 Multisampler/ 1260 Hybrid Multisampler • G5668A 1260 Bio-inert Multisampler • G7137A/B 1290 Bio Multisampler/ 1290 Hybrid Multisampler

Troubleshooting and Diagnostics

Overview of Available Tests and Tools

Maintenance tasks	Modules
Exchange Rotor Seal	<ul style="list-style-type: none"> • G7129A/B/C 1260 Vialsampler/ 1290 Vialsampler • G7167A/B/C (Dual-Needle Supported) 1260 Multisampler/ 1290 Multisampler/ 1260 Hybrid Multisampler • G5668A 1260 Bio-inert Multisampler • G7137A/B 1290 Bio Multisampler/ 1290 Hybrid Multisampler
Exchange Gripper	<ul style="list-style-type: none"> • G7129A/B/C 1260 Vialsampler/ 1290 Vialsampler
Sample ID Reader Cleaning	<ul style="list-style-type: none"> • G4756A Sample ID Reader
Exchange a Column	<ul style="list-style-type: none"> • G7116A/B 1260 Multicolumn Thermostat/ 1290 Multicolumn Thermostat
Exchange a Heat Exchanger	<ul style="list-style-type: none"> • G7116A/B 1260 Multicolumn Thermostat/ 1290 Multicolumn Thermostat
Exchange Lamp Housing Window	<ul style="list-style-type: none"> • G7123B 1290 Fluorescence Detector
Replace Deuterium Lamp	<ul style="list-style-type: none"> • G7114A/B 1260 Variable Wavelength Detector/ 1290 Variable Wavelength Detector • G7115A 1260 Diode Array Detector WR • G7117A/B/C 1290 Diode Array Detector FS/ 1290 Diode Array Detector/ 1260 Diode Array Detector HS • G7123B 1290 Fluorescence Detector • G7165A 1260 Multiple Wavelength Detector
Replace Hg-Xe Lamp	<ul style="list-style-type: none"> • G7123B 1290 Fluorescence Detector
Replace Flow Cell	<ul style="list-style-type: none"> • G7123B 1290 Fluorescence Detector
Wavelength Calibration	<ul style="list-style-type: none"> • G7114A/B 1260 Variable Wavelength Detector/ 1290 Variable Wavelength Detector • G7115A 1260 Diode Array Detector WR • G7117A/B/C 1290 Diode Array Detector FS/ 1290 Diode Array Detector/ 1260 Diode Array Detector HS • G7121A/B 1260 Fluorescence Detector/ 1260 Fluorescence Detector Spectra • G7123B 1290 Fluorescence Detector • G7165A 1260 Multiple Wavelength Detector

Diagnostic Procedures

Table 11: Overview of tasks and related modules

Maintenance tasks	Modules
Pump Leak Rate Test	<ul style="list-style-type: none"> • G7110B 1260 Isocratic Pump • G7111A/B 1260 Quaternary Pump VL/ 1260 Quaternary Pump • G7112B 1260 Binary Pump • G7104A/C 1290 Flexible Pump/ 1260 Flexible Pump • G7120A 1290 High-Speed Pump • G5654A 1260 Bio-inert Quaternary Pump • G7131A/C 1290 Bio Flexible Pump/ 1260 Bio Flexible Pump • G7132A 1290 Bio High-Speed Pump
System Pressure Test	<ul style="list-style-type: none"> • G7110B 1260 Isocratic Pump • G7111A/B 1260 Quaternary Pump VL/ 1260 Quaternary Pump • G7112B 1260 Binary Pump • G7104A/C 1290 Flexible Pump/ 1260 Flexible Pump • G7120A 1290 High-Speed Pump • G5654A 1260 Bio-inert Quaternary Pump • G7131A/C 1290 Bio Flexible Pump/ 1260 Bio Flexible Pump • G7132A 1290 Bio High-Speed Pump
Thermostat Test	<ul style="list-style-type: none"> • G7116A/B 1260 Multicolumn Thermostat/ 1290 Multicolumn Thermostat
Cell Test	<ul style="list-style-type: none"> • G7114A/B 1260 Variable Wavelength Detector/ 1290 Variable Wavelength Detector • G7115A 1260 Diode Array Detector WR • G7117A/B/C 1290 Diode Array Detector FS/ 1290 Diode Array Detector/ 1260 Diode Array Detector HS • G7165A 1260 Multiple Wavelength Detector
Dark Current Test	<ul style="list-style-type: none"> • G7114A/B 1260 Variable Wavelength Detector/ 1290 Variable Wavelength Detector • G7115A 1260 Diode Array Detector WR • G7117A/B/C 1290 Diode Array Detector FS/ 1290 Diode Array Detector/ 1260 Diode Array Detector HS • G7165A 1260 Multiple Wavelength Detector

Troubleshooting and Diagnostics

Overview of Available Tests and Tools

Maintenance tasks	Modules
Holmium Oxide Test	<ul style="list-style-type: none"> • G7114A/B 1260 Variable Wavelength Detector/ 1290 Variable Wavelength Detector • G7115A 1260 Diode Array Detector WR • G7165A 1260 Multiple Wavelength Detector
Intensity Test	<ul style="list-style-type: none"> • G7114A/B 1260 Variable Wavelength Detector/ 1290 Variable Wavelength Detector • G7115A 1260 Diode Array Detector WR • G7117A/B/C 1290 Diode Array Detector FS/ 1290 Diode Array Detector/ 1260 Diode Array Detector HS • G7121A/B 1260 Fluorescence Detector/ 1260 Fluorescence Detector Spectra • G7165A 1260 Multiple Wavelength Detector
Lamp Intensity Scan	<ul style="list-style-type: none"> • G7123B 1290 Fluorescence Detector
Wavelength Verification Test	<ul style="list-style-type: none"> • G7115A 1260 Diode Array Detector WR • G7117A/B/C 1290 Diode Array Detector FS/ 1290 Diode Array Detector/ 1260 Diode Array Detector HS • G7165A 1260 Multiple Wavelength Detector
Wavelength Accuracy Test	<ul style="list-style-type: none"> • G7121A/B 1260 Fluorescence Detector/ 1260 Fluorescence Detector Spectra • G7123B 1290 Fluorescence Detector

Maintenance and Troubleshooting Tools

Maintenance Procedures

Guided Maintenance is available with the InfinityLab Assist Control Software. Guided Maintenance gives step-by-step guidance to perform typical maintenance procedures. Some procedures require the instrument to be moved to maintenance position so that maintenance can be completed. This is integrated into the step-by-step workflow. Other maintenance instructions show the complete procedure with illustrations, so you know how to carry out the procedure directly at the instrument. The procedures also contain information on parts required, the estimated duration and warnings and cautions when working with the instrument.

The following figure shows the **Vialsampler Exchange Needle and Seat** procedure overview including time required, steps to be performed, tools and parts required, as well as all safety relevant information.

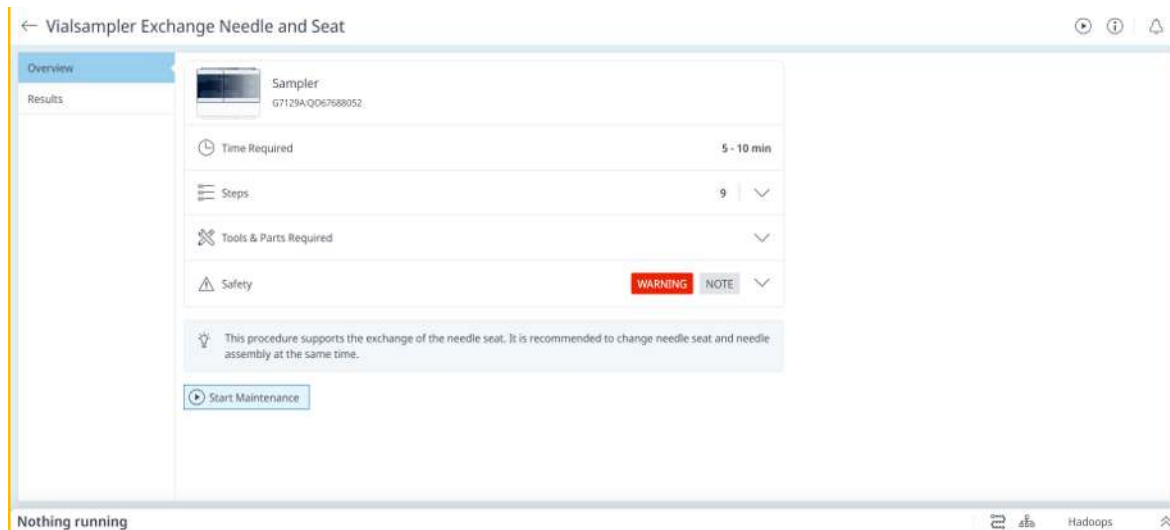

Figure 9: Overview for procedure: Vialsampler Exchange Needle and Seat

Troubleshooting Tools

The troubleshooting guide is located in **Health > Troubleshooting**. Check the possible instrument issues based on the symptom displayed by the instrument:

- Baseline
- Peak Shape
- Pressure
- Retention
- Tuning (when a G6160B Pro iQ MS or G6170A Pro iQ Plus MS is present)

The shown issues are ranked based on their likelihood. Tips and tricks should help with troubleshooting the issue.



Review the detector method settings and ensure that they are suitable for the given analytical problem. Some detector parameters, such as wavelength or data rate, can have a significant impact on the detector signal.



Remove the flow cell from the flow path to help determine if the flow/flow cell is the source of the baseline issue.

Figure 10: Troubleshooting tips and tricks

The user-identified troubleshooting tool is displayed as first item in the list. It contains the specific issues only applicable to the modules present in the system. This is context sensitive troubleshooting information.

In addition to the textual troubleshooting, various actions are also linked that help to solve/troubleshoot the issue.

The second troubleshooting tool available with the InfinityLab Assist Control Software is the **Assisted Troubleshooting**. Assisted troubleshooting is enabled when a specific error occurs. The user then receives step-by-step guidance to troubleshoot the issue.



8 Maintenance Tasks

This chapter describes the maintenance of the module.

Safety Information Related to Maintenance 107

Overview of Maintenance 109

Cleaning the Module 110

Remove and Install the Display Holder 111

Removing the Display Holder from the Assist Hub 111

Removing the Display Holder from the Assist Interface 113

Troubleshooting an Unresponsive Assist Interface 114

Unfreeze the Assist Interface 115

Safety Information Related to Maintenance

WARNING

Fire and damage to the module

Wrong fuses

- Make sure that only fuses with the required rated current and of the specified type (super-fast, fast, time delay etc) are used for replacement.
 - The use of repaired fuses and the short-circuiting of fuse-holders must be avoided.
-

WARNING

Personal injury or damage to the product

Agilent is not responsible for any damages caused, in whole or in part, by improper use of the products, unauthorized alterations, adjustments or modifications to the products, failure to comply with procedures in Agilent product user guides, or use of the products in violation of applicable laws, rules or regulations.

- Use your Agilent products only in the manner described in the Agilent product user guides.
-

WARNING

Electrical shock

Repair work at the module can lead to personal injuries, e.g. shock hazard, when the cover is opened.

- Do not remove the cover of the module.
 - Only certified persons are authorized to carry out repairs inside the module.
-

WARNING

Sharp metal edges

Sharp-edged parts of the equipment may cause injuries.

- To prevent personal injury, be careful when getting in contact with sharp metal areas.
-

WARNING

Toxic, flammable and hazardous solvents, samples and reagents

The handling of solvents, samples and reagents can hold health and safety risks.

- When working with these substances observe appropriate safety procedures (for example by wearing goggles, safety gloves and protective clothing) as described in the material handling and safety data sheet supplied by the vendor, and follow good laboratory practice.
- The volume of substances should be reduced to the minimum required for the analysis.
- Do not operate the instrument in an explosive atmosphere.

CAUTION

Safety standards for external equipment

- If you connect external equipment to the instrument, make sure that you only use accessory units tested and approved according to the safety standards appropriate for the type of external equipment.

Overview of Maintenance

The InfinityLab Assist Hub requires no maintenance (simple repairs).

Cleaning the Module

To keep the module case clean, use a soft cloth slightly dampened with water, or a solution of water and mild detergent. Avoid using organic solvents for cleaning purposes. They can cause damage to plastic parts.

WARNING

Liquid dripping into the electronic compartment of your module can cause shock hazard and damage the module

- **Do not use an excessively damp cloth during cleaning.**
- **Drain all solvent lines before opening any connections in the flow path.**

NOTE

A solution of 70 % isopropanol and 30 % water might be used if the surface of the module needs to be disinfected.

Remove and Install the Display Holder

Removing the Display Holder from the Assist Hub

- 1 Remove the Power over Ethernet (PoE) cable from the Assist Hub.

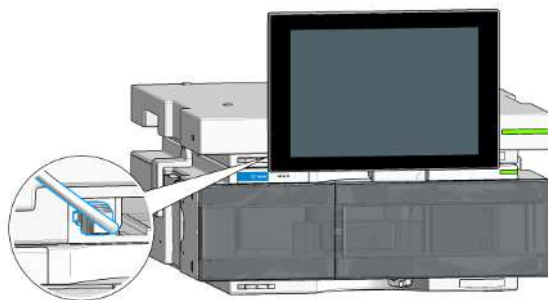

- 2 Press the button underneath the Assist Hub to release the Display Holder from the Assist Hub.

NOTE

When combining with certain modules (for example, Vialsampler or Multisampler) in the stack, you must remove the safety clips to access the button.

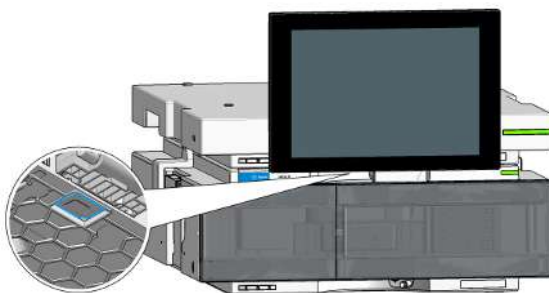

Maintenance Tasks

Remove and Install the Display Holder

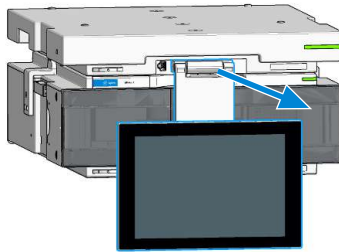

For details on installing the Display Holder, see [Installing the Display Holder](#) on page 29.

Removing the Display Holder from the Assist Interface

Tools required

Qty.	p/n	Description
1	 5023-3138	Reversible Screwdriver + Blade 1,0 x 5,5

- 1 Release the Display Holder from the Assist Interface. Insert a blade screwdriver into the intended opening and lift the Display Holder slightly until it can be released.

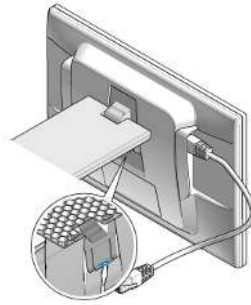

- 2 Slide the Display Holder out of the slot of the Assist Interface.

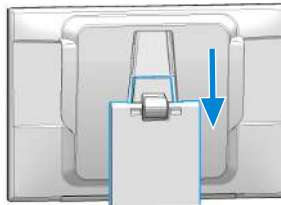

For details on installing the Display Holder, see [Installing the Display Holder](#) on page 29.

Troubleshooting an Unresponsive Assist Interface

In rare cases, the Assist Interface may freeze. The following signs indicate this issue:

- You are unable to log in.
- The screen does not reflect the actual instrument parameters.
- You are unable to perform any operations.

To resolve the issue, see [Unfreeze the Assist Interface](#) on page 115. If the instructions cannot resolve the problem, please contact your Agilent service representative.

NOTE

You can continue working with InfinityLab Assist by using your Web browser.

For a detailed description of how to access InfinityLab Assist, see [Using the Assist Control Software Browser User Interface](#) on page 52.

Unfreeze the Assist Interface

- 1 Disconnect the Power over Ethernet (PoE) cable that connects the Assist Interface to the Assist Hub.

For details, see [Module-Specific Hardware Information](#) on page 146.

- 2 Reconnect the cable.

If the problem persists, proceed to the next step.

- 3 Turn the Assist Hub OFF and ON again using the power button.

For details, see [Module-Specific Hardware Information](#) on page 146.

If the problem persists, reset the Assist Hub.

Reset the Assist Hub

NOTE

The reset will lead to a complete data loss and a reset to factory settings. It is strongly recommended that you create a backup before you reset the Assist Hub. For details about creating a backup, see the corresponding section in the *Agilent InfinityLab Assist Administration Manual (InfinityLab-Assist-AdmMa-en-D0123783.pdf, D0123783)*.

- 1 Turn OFF the Assist Hub.
- 2 Use a 8710-1977 (Hex key, 0.9 mm, long arm metric) to press and hold the reset button.
- 3 Turn ON the Assist Hub and continue pressing the reset button until the Status LED starts flashing red.
 - ✓ Once the flashing has stopped, the reset is complete. The Assist Hub turns on.

If the instructions cannot resolve the problem, please contact your Agilent service representative.



9 Parts and Materials for Maintenance

This chapter provides information on parts and materials for maintenance.

Standard Parts for Maintenance 117





Accessory Kits 118

Standard Parts for Maintenance



The InfinityLab Assist Hub requires no maintenance (simple repairs). For information on orderable replacement parts, see [Accessory Kits](#) on page 118.

Accessory Kits

The G7180-68705 (Accessory Kit) of the InfinityLab Assist Hub (G7180A) contains the following parts:

Qty.	p/n	Description
1	 5181-1516	CAN cable, Agilent module to module, 0.5 m
2	 5023-0203	Cross-over network cable, shielded, 3 m
1	 5720-0022	Display Holder Base Assembly
1	 G7180-68000	Assist Safety Clip Kit

InfinityLab Assist Interface (G7179A) Shipment Kit:

Qty.	p/n	Description
1	 G7179-64000	InfinityLab Assist Interface
1	 5039-0050	Power over Ethernet (PoE) Cable



10 Identifying Cables

This chapter provides information on cables used with the modules.

Cable Overview 120

Analog Cables 122

Remote Cables 124

BCD Cables 128

CAN/LAN Cables 130

RS-232 Cables 131

USB 132

Cable Overview

NOTE

Never use cables other than the ones supplied by Agilent Technologies to ensure proper functionality and compliance with safety or EMC regulations.

Analog cables

p/n	Description
35900-60750	Agilent 35900A A/D converter
01046-60105	Analog cable (BNC to general purpose, spade lugs)

Remote cables

p/n	Description
5188-8029	ERI to general purpose
5188-8044	Remote Cable ERI – ERI
5188-8045	Remote Cable APG – ERI
5188-8059	ERI-Extension-Cable 1.2 m
5061-3378	Remote Cable to 35900 A/D converter
01046-60201	Agilent module to general purpose
5188-8057	Fraction Collection ERI remote Y-cable

CAN cables

p/n	Description
5181-1516	CAN cable, Agilent module to module, 0.5 m
5181-1519	CAN cable, Agilent module to module, 1 m

LAN cables

p/n	Description
5023-0203	Cross-over network cable, shielded, 3 m (for point to point connection)
5023-0202	Twisted pair network cable, shielded, 7 m (for point to point connection)

RS-232 cables

p/n	Description
RS232-61601	RS-232 cable, 2.5 m Instrument to PC, 9-to-9 pin (female). This cable has special pin-out, and is not compatible with connecting printers and plotters. It is also called "Null Modem Cable" with full handshaking where the wiring is made between pins 1-1, 2-3, 3-2, 4-6, 5-5, 6-4, 7-8, 8-7, 9-9.
5181-1561	RS-232 cable, 8 m

USB cables

p/n	Description
5188-8050	USB A M-USB Mini B 3 m (PC-Module)
5188-8049	USB A F-USB Mini B M OTG (Module to Flash Drive)

Analog Cables

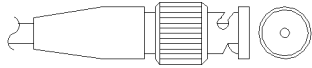

One end of these cables provides a BNC connector to be connected to Agilent modules. The other end depends on the instrument to which connection is being made.

Agilent Module to 35900 A/D converters

p/n 35900-60750	35900	Pin Agilent module	Signal Name
	1		Not connected
	2	Shield	Analog -
	3	Center	Analog +

Agilent Module to BNC Connector

p/n 8120-1840	Pin BNC	Pin Agilent module	Signal Name
	Shield	Shield	Analog -
	Center	Center	Analog +

Agilent Module to General Purpose

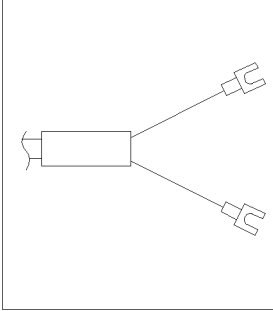
p/n 01046-60105	Pin	Pin Agilent module	Signal Name
	1		Not connected
	2	Black	Analog -
	3	Red	Analog +

Remote Cables

ERI (Enhanced Remote Interface)

- 5188-8029 ERI to general purpose (D-Sub 15 pin male - open end)
- 5188-8044 ERI to ERI (D_Sub 15 pin male - male)
- 5188-8059 ERI-Extension-Cable 1.2 m (D-Sub15 pin male / female)

p/n 5188-8029	pin	Color code	Enhanced Remote	Classic Remote	Active (TTL)
<p>D-Sub female 15way user's view to connector</p>	1	white	IO1	START REQUEST	Low
	2	brown	IO2	STOP	Low
	3	green	IO3	READY	High
	4	yellow	IO4	PEAK DETECT	Low
	5	grey	IO5	POWER ON	High
	6	pink	IO6	SHUT DOWN	Low
	7	blue	IO7	START	Low
	8	red	IO8	PREPARE	Low
	9	black	1wire DATA		
	10	violet	DGND		
	11	grey-pink	+5V ERI out		
	12	red-blue	PGND		
	13	white-green	PGND		
	14	brown-green	+24V ERI out		
	15	white-yellow	+24V ERI out		
	NC	yellow-brown			

NOTE

Configuration is different with old firmware revisions.
The configuration for IO4 and IO5 is swapped for modules with firmware lower than D.07.10.

NOTE

Peak Detection is used for LCMS systems connected with the Fraction Collection Remote Y-Cable (5188-8057).

Identifying Cables

Remote Cables

- 5188-8045 ERI to APG (Connector D_Subminiature 15 pin (ERI), Connector D_Subminiature 9 pin (APG))

p/n 5188-8045	Pin (ERI)	Signal	Pin (APG)	Active (TTL)
	10	GND	1	
	1	Start Request	9	Low
	2	Stop	8	Low
	3	Ready	7	High
	5	Power on	6	High
	4	Future	5	
	6	Shut Down	4	Low
	7	Start	3	Low
	8	Prepare	2	Low
	Ground	Cable Shielding	NC	

Identifying Cables

Remote Cables

- 5188-8057 ERI to APG and RJ45 (Connector D_Subminiature 15 pin (ERI), Connector D_Subminiature 9 pin (APG), Connector plug Cat5e (RJ45))

Table 12: 5188-8057 ERI to APG and RJ45

p/n 5188-8057	Pin (ERI)	Signal	Pin (APG)	Active (TTL)	Pin (RJ45)
	10	GND	1		5
	1	Start Request	9	High	
	2	Stop	8	High	
	3	Ready	7	High	
	4	Fraction Trigger	5	High	4
	5	Power on	6	High	
	6	Shut Down	4	High	
	7	Start	3	High	
	8	Prepare	2	High	
	Ground	Cable Shielding	NC		



One end of these cables provides an Agilent Technologies APG (Auxiliary Port Group) remote connector to be connected to Agilent modules. The other end depends on the instrument to be connected to.

Agilent Module to Agilent 35900 A/D Converters

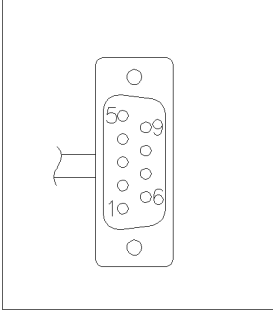
p/n 5061-3378	Pin 35900 A/D	Pin Agilent module	Signal Name	Active (TTL)
	1 - White	1 - White	Digital ground	
	2 - Brown	2 - Brown	Prepare run	Low
	3 - Gray	3 - Gray	Start	Low
	4 - Blue	4 - Blue	Shut down	Low
	5 - Pink	5 - Pink	Not connected	
	6 - Yellow	6 - Yellow	Power on	High
	7 - Red	7 - Red	Ready	High
	8 - Green	8 - Green	Stop	Low
	9 - Black	9 - Black	Start request	Low

Agilent Module to General Purpose

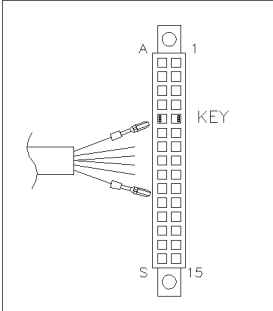
p/n 01046-60201	Wire Color	Pin Agilent module	Signal Name	Active (TTL)
	White	1	Digital ground	
	Brown	2	Prepare run	Low
	Gray	3	Start	Low
	Blue	4	Shut down	Low
	Pink	5	Not connected	
	Yellow	6	Power on	High
	Red	7	Ready	High
	Green	8	Stop	Low
	Black	9	Start request	Low

BCD Cables

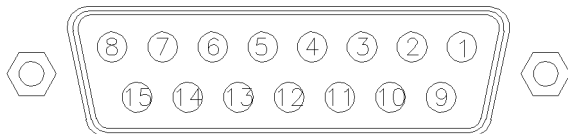

One end of these cables provides a 15-pin BCD connector to be connected to the Agilent modules. The other end depends on the instrument to be connected to

Agilent Module to General Purpose

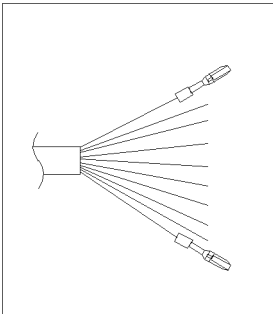
p/n G1351-81600	Wire Color	Pin Agilent module	Signal Name	BCD Digit
	Green	1	BCD 5	20
	Violet	2	BCD 7	80
	Blue	3	BCD 6	40
	Yellow	4	BCD 4	10
	Black	5	BCD 0	1
	Orange	6	BCD 3	8
	Red	7	BCD 2	4
	Brown	8	BCD 1	2
	Gray	9	Digital ground	Gray
	Gray/pink	10	BCD 11	800
	Red/blue	11	BCD 10	400
	White/green	12	BCD 9	200
	Brown/green	13	BCD 8	100
	not connected	14		
	not connected	15	+ 5 V	Low

Agilent Module to 3396 Integrators

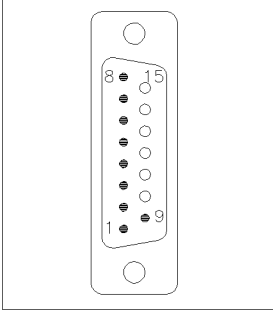
p/n 03396-60560	Pin 3396	Pin Agilent module	Signal Name	BCD Digit
	1	1	BCD 5	20
	2	2	BCD 7	80
	3	3	BCD 6	40
	4	4	BCD 4	10
	5	5	BCD0	1
	6	6	BCD 3	8
	7	7	BCD 2	4
	8	8	BCD 1	2
	9	9	Digital ground	
	NC	15	+ 5 V	Low

CAN/LAN Cables

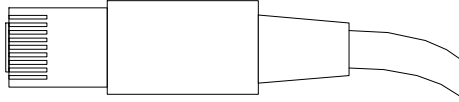

Both ends of this cable provide a modular plug to be connected to Agilent modules CAN or LAN connectors.

Can Cables

p/n	Description
5181-1516	CAN cable, Agilent module to module, 0.5 m
5181-1519	CAN cable, Agilent module to module, 1 m

LAN Cables

p/n	Description
5023-0203	Cross-over network cable, shielded, 3 m (for point to point connection)
5023-0202	Twisted pair network cable, shielded, 7 m (for point to point connection)

RS-232 Cables

p/n	Description
RS232-61601	RS-232 cable, 2.5 m Instrument to PC, 9-to-9 pin (female). This cable has special pin-out, and is not compatible with connecting printers and plotters. It is also called "Null Modem Cable" with full handshaking where the wiring is made between pins 1-1, 2-3, 3-2, 4-6, 5-5, 6-4, 7-8, 8-7, 9-9.
5181-1561	RS-232 cable, 8 m

USB

To connect a USB Flash Drive use a USB OTG cable with Mini-B plug and A socket.

p/n	Description
5188-8050	USB A M-USB Mini B 3 m (PC-Module)
5188-8049	USB A F-USB Mini B M OTG (Module to Flash Drive)



11

Hardware Information

This chapter describes the module in more detail on hardware and electronics.

General Hardware Information 134

Electrical Connections 134

Interfaces 136

Overview Interfaces 139

Instrument Layout 144

Early Maintenance Feedback (EMF) 145

Module-Specific Hardware Information 146

General Hardware Information

This section provides detailed hardware information.

Electrical Connections

- The CAN bus is a serial bus with high-speed data transfer. The two connectors for the CAN bus are used for internal module data transfer and synchronization.
- With the appropriate software, the LAN connector may be used to control the module from a computer through a LAN connection. This connector is activated and can be configured with the configuration switch.
- The USB connector may be used for service related workflows.
- The power input socket accepts a line voltage of 100 – 240 VAC \pm 10 % with a line frequency of 50 or 60 Hz. Maximum power consumption varies by module. There is no voltage selector on your module because the power supply has wide-ranging capability. There are no externally accessible fuses because automatic electronic fuses are implemented in the power supply.

WARNING

**Electric shock due to insufficient insulation of connected instruments
Personal injury or damage to the instrument**

- **Any other instruments connected to this instrument shall be approved to a suitable safety standard and must include reinforced insulation from the mains.**

NOTE

Never use cables other than the ones supplied by Agilent Technologies to ensure proper functionality and compliance with safety or EMC regulations.

Rear View of the Module

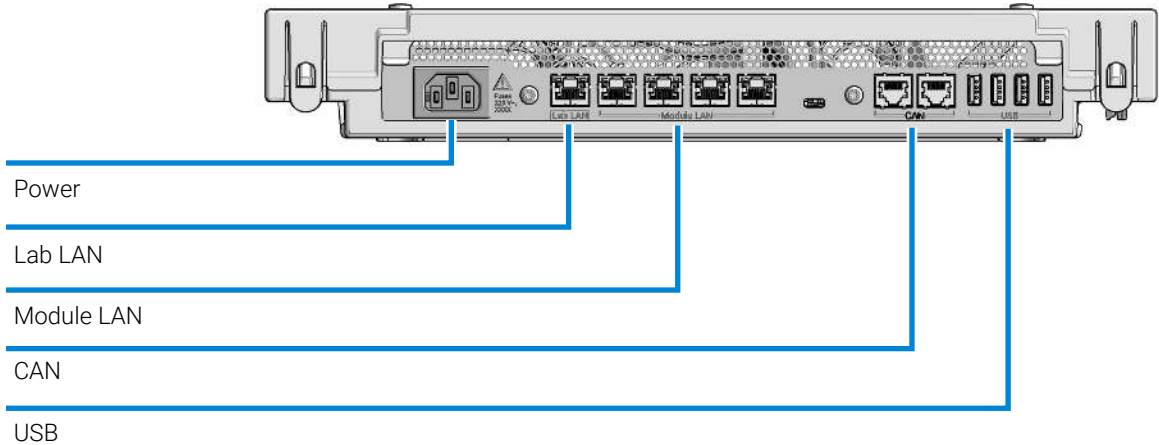

Figure 11: Rear view of the Agilent InfinityLab Assist Hub (G7180A)

Serial Number Information

The serial number information on the instrument labels provide the following information:

CCXZZ00000	Format
CC	Country of manufacturing <ul style="list-style-type: none"> • DE = Germany • JP = Japan • CN = China • RO = Romania
X	Alphabetic character A-Z (used by manufacturing)
ZZ	Alpha-numeric code 0-9, A-Z, where each combination unambiguously denotes a module (there can be more than one code for the same module)
00000	Serial number

Interfaces

The Agilent InfinityLab LC Series modules provide the following interfaces:

Table 13: Agilent InfinityLab LC Series interfaces

Module	CAN	USB	LAN (on-board)	RS-232	Analog	APG (A) / ERI (E)	Special
Pumps							
G7104A/C, G7131A/C	2	No	Yes	Yes	1	A	
G7110B	2	Yes	Yes	No	No	E	
G7111A/B, G5654A	2	Yes	Yes	No	No	E	
G7112B	2	Yes	Yes	No	No	E	
G7120A, G7132A	2	No	Yes	Yes	1	A	
G7161A/B	2	Yes	Yes	No	No	E	
Samplers							
G7129A/B/C	2	Yes	Yes	No	No	E	
G7167A/B/C, G7137A/B, G5668A, G3167A/B	2	Yes	Yes	No	No	E	
G7157A	2	Yes	Yes	No	No	E	
Detectors							
G7114A/B	2	Yes	Yes	No	1	E	
G7115A	2	Yes	Yes	No	1	E	
G7117A/B/C	2	Yes	Yes	No	1	E	
G7121A/B	2	Yes	Yes	No	1	E	
G7123B	2	Yes	Yes	No	1	E	
G7162A/B	2	Yes	Yes	No	1	E	
G7165A	2	Yes	Yes	No	1	E	
Fraction Collectors							
G7158B	2	Yes	Yes	No	No	E	
G7159B	2	Yes	Yes	No	No	E	

Module	CAN	USB	LAN (on-board)	RS-232	Analog	APG (A) / ERI (E)	Special
G7166A	2	No	No	No	No	No	Requires a host module with on-board LAN with minimum FW B.06.40 or C.06.40, or with additional G1369C LAN Card
G1364E/F, G5664B	2	Yes	Yes	No	No	E	THERMOSTAT for G1330B
Others							
G1170A	2	No	No	No	No	No	Requires a host module with on-board LAN or with additional G1369C LAN Card.
G7116A/B	2	No	No	No	No	No	Requires a host module with on-board LAN or with additional G1369C LAN Card.
G7122A	No	No	No	Yes	No	A	
G7170B	2	No	No	No	No	No	Requires a host module with on-board LAN with minimum FW B.06.40 or C.06.40, or with additional G1369C LAN Card
G7175A	2	No	No	No	No	No	Requires a host module with on-board LAN or with additional G1369C LAN Card.

NOTE

LAN connection is made between at least one of the Agilent modules and the Control PC.

- If an Assist Hub is installed, connect the laboratory (or Control PC) LAN to the Lab LAN port of the Assist Hub.
- If an Assist Hub is installed, connect additional LAN connections from the detectors and pumps to the Module LAN ports of the Assist Hub.
- If an Assist Hub is NOT installed and a detector is installed, connect the LAN to this detector.
- If an Assist Hub is NOT installed and there are multiple detectors with spectral capabilities, consider using additional LAN connections for each detector.

Hardware Information

General Hardware Information

- CAN connectors as interface to other modules
- LAN connector as interface to the control software
- RS-232C as interface to a computer
- USB (Universal Series Bus) for service workflows
- REMOTE connector as interface to other Agilent products
- Analog output connector for signal output

Overview Interfaces

CAN

The CAN is inter-module communication interface. It is a 2-wire serial bus system supporting high speed data communication and real-time requirement.

LAN

The modules have either an interface slot for a LAN card (e.g. Agilent G1369B/C LAN Interface) or they have an on-board LAN interface (e.g. detectors G1315C/D DAD and G1365C/D MWD). This interface allows the control of the module/system via a PC with the appropriate control software. Some modules have neither on-board LAN nor an interface slot for a LAN card (e.g. G1170A Valve Drive or G4227A Flexible Cube). These are hosted modules and require a Host module with firmware B.06.40 or later or with additional G1369C LAN Card.

NOTE

LAN connection is made between at least one of the Agilent modules and the Control PC.

- If an Assist Hub is installed, connect the laboratory (or Control PC) LAN to the Lab LAN port of the Assist Hub.
- If an Assist Hub is installed, connect additional LAN connections from the detectors and pumps to the Module LAN ports of the Assist Hub.
- If an Assist Hub is NOT installed and a detector is installed, connect the LAN to this detector.
- If an Assist Hub is NOT installed and there are multiple detectors with spectral capabilities, consider using additional LAN connections for each detector.

RS-232C (Serial)

NOTE

There is no configuration possible on main boards with on-board LAN. These are pre-configured for 19200 baud, 8 data bit with no parity and one start bit and one stop bit are always used (not selectable).

The RS-232C is designed as DCE (data communication equipment) with a 9-pin male SUB-D type connector. The pins are defined as:

Table 14: RS-232C Connection Table

Pin	Direction	Function
1	In	DCD
2	In	RxD
3	Out	TxD
4	Out	DTR
5		Ground
6	In	DSR
7	Out	RTS
8	In	CTS
9	In	RI

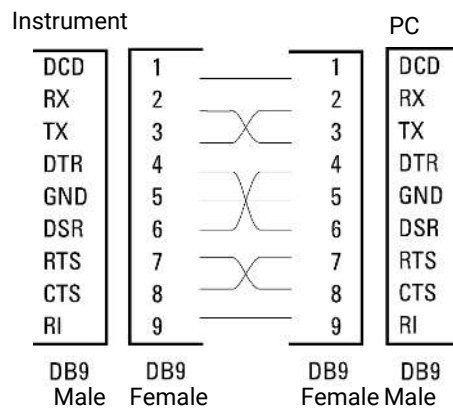

Figure 12: RS-232 Cable

Analog Signal Output

The analog signal output can be distributed to a recording device. For details refer to the description of the module's mainboard.

APG Remote

The APG Remote connector may be used in combination with other analytical instruments from Agilent Technologies if you want to use features as common shut down, prepare, and so on.

Remote control allows easy connection between single instruments or systems to ensure coordinated analysis with simple coupling requirements.

The subminiature D connector is used. The module provides one remote connector which is inputs/outputs (wired- or technique).

To provide maximum safety within a distributed analysis system, one line is dedicated to **SHUT DOWN** the system's critical parts in case any module detects a serious problem. To detect whether all participating modules are switched on or properly powered, one line is defined to summarize the **POWER ON** state of all connected modules. Control of analysis is maintained by signal readiness **READY** for next analysis, followed by **START** of run and optional **STOP** of run triggered on the respective lines. In addition **PREPARE** and **START REQUEST** may be issued. The signal levels are defined as:

- standard TTL levels (0 V is logic true, + 5.0 V is false),
- fan-out is 10 ,
- input load is 2.2 kOhm against + 5.0 V, and
- output are open collector type, inputs/outputs (wired- or technique).

NOTE

All common TTL circuits operate with a 5 V power supply. A TTL signal is defined as "low" or L when between 0 V and 0.8 V and "high" or H when between 2.0 V and 5.0 V (with respect to the ground terminal).

Table 15: Remote Signal Distribution

Pin	Signal	Description
1	DGND	Digital ground
2	PREPARE	(L) Request to prepare for analysis (for example, calibration, detector lamp on). Receiver is any module performing pre-analysis activities.

Hardware Information

General Hardware Information

Pin	Signal	Description
3	START	(L) Request to start run / timetable. Receiver is any module performing run-time controlled activities.
4	SHUT DOWN	(L) System has serious problem (for example, leak: stops pump). Receiver is any module capable to reduce safety risk.
5		Not used
6	POWER ON	(H) All modules connected to system are switched on. Receiver is any module relying on operation of others.
7	READY	(H) System is ready for next analysis. Receiver is any sequence controller.
8	STOP	(L) Request to reach system ready state as soon as possible (for example, stop run, abort or finish and stop injection). Receiver is any module performing run-time controlled activities.
9	START REQUEST	(L) Request to start injection cycle (for example, by start key on any module). Receiver is the autosampler.

USB (Universal Serial Bus)

The USB replaced the RS-232 and is used for service workflows, only.

For the InfinityLab Assist, the USB connector supports USB storage media of type exFAT, FAT32, EXT4. It can be used to perform software updates, data storage, back up, or Import/Export of Tasks & Settings.

Special Interfaces

There is no special interface for this module.

Instrument Layout

The industrial design of the module incorporates several innovative features. It uses Agilent's E-PAC concept for the packaging of electronics and mechanical assemblies. This concept is based upon the use of expanded polypropylene (EPP) layers of foam plastic spacers in which the mechanical and electronic boards components of the module are placed. This pack is then housed in a metal inner cabinet which is enclosed by a plastic external cabinet. The advantages of this packaging technology are:

- virtual elimination of fixing screws, bolts or ties, reducing the number of components and increasing the speed of assembly/disassembly,
- the plastic layers have air channels molded into them so that cooling air can be guided exactly to the required locations,
- the plastic layers help cushion the electronic and mechanical parts from physical shock, and
- the metal inner cabinet shields the internal electronics from electromagnetic interference and also helps to reduce or eliminate radio frequency emissions from the instrument itself.

Early Maintenance Feedback (EMF)

Maintenance requires the exchange of components that are subject to wear or stress. Ideally, the frequency at which components are exchanged should be based on the intensity of use of the module and the analytical conditions, and not on a predefined time interval. The early maintenance feedback (EMF) feature monitors the use of specific components in the instrument, and provides feedback when the user-selectable limits have been exceeded. The visual feedback in the user interface provides an indication that maintenance procedures should be scheduled.

EMF Counters

EMF counters increment with use and can be assigned a maximum limit which provides visual feedback in the user interface when the limit is exceeded. Some counters can be reset to zero after the required maintenance procedure.

The detector provides the following EMF counters:

- Hg-Xe lamp On-Time
- Number of Hg-Xe lamp ignitions

Using the EMF Counters

The user-settable **EMF** limits for the **EMF Counters** enable the early maintenance feedback to be adapted to specific user requirements. The useful maintenance cycle is dependent on the requirements for use. Therefore, the definition of the maximum limits needs to be determined based on the specific operating conditions of the instrument.

Setting the EMF Limits

The setting of the **EMF** limits must be optimized over one or two maintenance cycles. Initially the default **EMF** limits should be set. When instrument performance indicates maintenance is necessary, take note of the values displayed by the **EMF counters**. Enter these values (or values slightly less than the displayed values) as **EMF** limits, and then reset the **EMF counters** to zero. The next time the **EMF counters** exceed the new **EMF** limits, the **EMF** flag will be displayed, providing a reminder that maintenance needs to be scheduled.

Module-Specific Hardware Information

InfinityLab Assist Hub (G7180A)

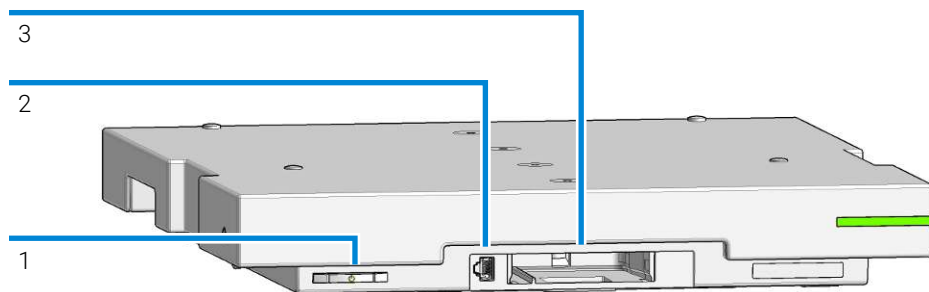

Figure 13: Front view of the InfinityLab Assist Hub (G7180A)

1	Power Button
2	Power over Ethernet (PoE) connection used for the Assist Interface
3	Garage for the Display Holder

Hardware Information

Module-Specific Hardware Information

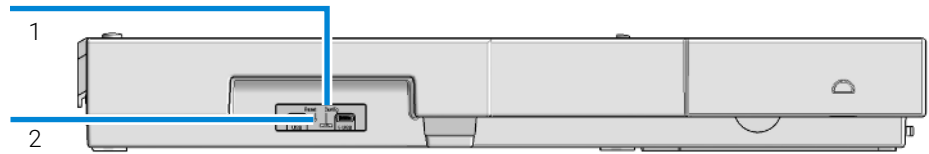

Figure 14: Left-side of the InfinityLab Assist Hub (G7180A)

-
- | | |
|-------|--|
| 1 | <p>2-position configuration switch:</p> <ul style="list-style-type: none"> • Front (right) position: to configure the IP address (by using specific data or automatically with DHCP server) • Back (left) position: the Assist Hub uses the default IP address (192.168.254.11) |
| <hr/> | |
| 2 | <p>Reset button:</p> <p>NOTE: The reset will lead to a complete data loss and a reset to factory settings. Turn OFF the Assist Hub. Use a 8710-1977 (Hex key, 0.9 mm, long arm metric) to press and hold the reset button.</p> <p>Turn ON the Assist Hub and continue pressing the reset button until the Status LED starts flashing red. Once the flashing has stopped, the reset is complete. The Assist Hub turns on.</p> |
-

InfinityLab Assist Interface (G7179A)



Figure 15: InfinityLab Assist Interface side view with Power over Ethernet (PoE) connector



Figure 16: InfinityLab Assist Interface side view with USB connectors

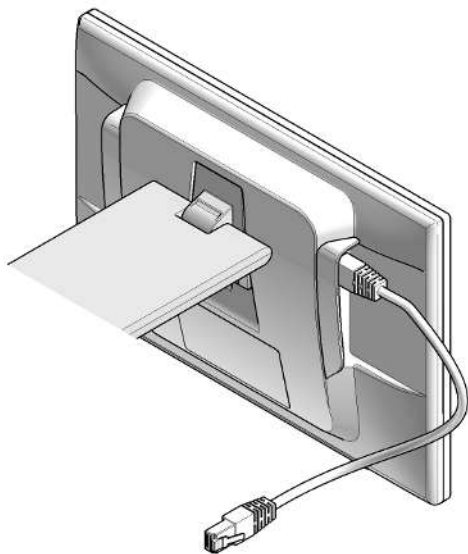

Figure 17: Back view of the InfinityLab Assist Interface

12

LAN Configuration

What You Have to Do First

The module has an on-board LAN communication interface.

- 1 Note the MAC (Media Access Control) address for further reference. The MAC or hardware address of the LAN interfaces is a world wide unique identifier. No other network device will have the same hardware address. The MAC address can be found on a label at the rear of the module.



Part number of the mainboard
Revision Code, Vendor, Year and Week of assembly
MAC address
Country of Origin

Figure 18: MAC label (example)

- 2 Connect the Assist **Lab LAN** interface to
 - the PC network card using a crossover network cable (point-to-point) or
 - a hub or switch using a standard LAN cable.

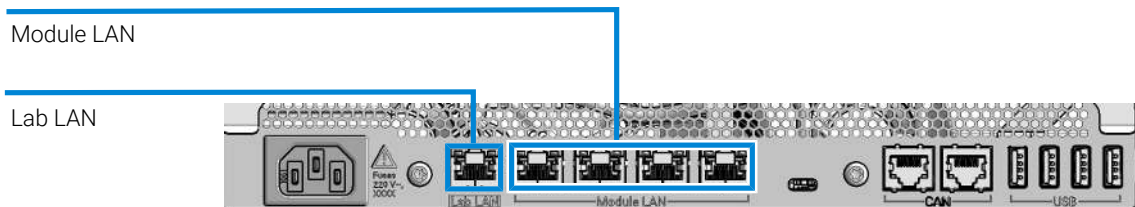

Figure 19: Location of LAN interfaces (InfinityLab Assist Hub)

TCP/IP Parameter Configuration

To operate properly in a network environment, the LAN interface must be configured with valid TCP/IP network parameters. These parameters are:

- IP address
- Subnet Mask
- Default Gateway

For more information, see [Setting Up the IP Address](#) on page 91.

Configuration Switch and Mode Selection

Configuration switch



Table 16: Overview of 1-bit configuration switch settings (G7180A)

SW 1	SW 2	SW 3	SW 4	SW 5	SW 6	SW 7	SW 8	Mode	Init Mode
0	-	-	-	-	-	-	-	Not supported	Configure the IP address (by using specific data or automatically with DHCP server)
1	-	-	-	-	-	-	-	Not supported	Configure default IP address (192.168.254.11)

Legend:

- SW = switch
- - = not available
- 0 = off (SW front = right)
- 1 = on (SW back = left)

Mode selection is not supported.

Manual Configuration

Manual configuration only alters the set of parameters stored in the non-volatile memory of the module. It never affects the currently active parameters. Therefore, manual configuration can be done at any time. A power cycle is mandatory to make the stored parameters become the active parameters, given that the initialization mode selection switches are allowing it.

PC Setup for Local Configuration

This procedure describes the change of the TCP/IP settings on your PC to match the module's default parameters in a local configuration.

The individual steps may vary depending on the operating system. Below you can find the steps to set up a static IP address in Windows 11.

- 1 Navigate to the settings on your PC (Windows **Start** menu > **Settings**).
- 2 Under **Network and internet**, select **Ethernet**.

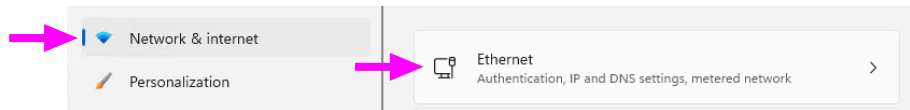

- 3 In section **IP assignment**, click **Edit**.

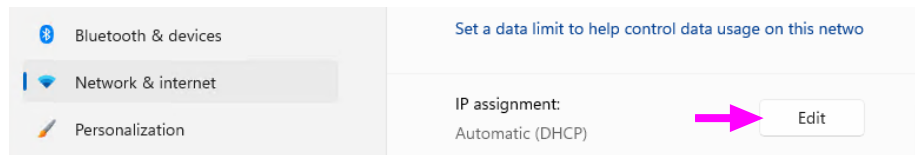

- 4 To edit the IP settings, select **Manual** from the drop-down list.

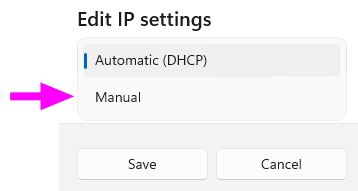

LAN Configuration

PC Setup for Local Configuration

- 5 Enable (toggle) the IPv4 connection and enter the following IP address settings:

Edit IP settings

Manual

IPv4

On

IP address

192.168.254.10

Subnet mask

255.255.255.0

Gateway

Preferred DNS

Preferred DNS encryption

Unencrypted only

Alternate DNS

Save Cancel

- 6 Save your configuration settings.

13

Appendix

This chapter provides additional information on safety, legal and web.

General Safety Information 156

Safety Standards 156

General 156

Before Applying Power 157

Ground the Instrument 157

Do Not Operate in an Explosive Atmosphere 158

Do Not Remove the Instrument Cover 158

Do Not Modify the Instrument 158

In Case of Damage 158

Solvent Information 159

Safety Symbols 160

Waste Electrical and Electronic Equipment (WEEE) Directive 163

Radio Interference 164

Sound Emission 165

Agilent Technologies on Internet 166

General Safety Information

The following general safety precautions must be observed during all phases of operation, service, and repair of this instrument. Failure to comply with these precautions or with specific warnings elsewhere in this manual violates safety standards of design, manufacture, and intended use of the instrument. Agilent Technologies assumes no liability for the customer's failure to comply with these requirements.

WARNING

Ensure the proper usage of the equipment.

The protection provided by the equipment may be impaired.

- **The operator of this instrument is advised to use the equipment in a manner as specified in this manual.**

Safety Standards

This is a Safety Class I instrument (provided with terminal for protective earthing) and has been manufactured and tested according to international safety standards.

General

Do not use this product in any manner not specified by the manufacturer. The protective features of this product may be impaired if it is used in a manner not specified in the operation instructions.

Before Applying Power

WARNING

Wrong voltage range, frequency or cabling

Personal injury or damage to the instrument

- Verify that the voltage range and frequency of your power distribution matches to the power specification of the individual instrument.
- Never use cables other than the ones supplied by Agilent Technologies to ensure proper functionality and compliance with safety or EMC regulations.
- Make all connections to the unit before applying power.

WARNING

Use of unsupplied cables

Using cables not supplied by Agilent Technologies can lead to damage of the electronic components or personal injury.

- Never use cables other than the ones supplied by Agilent Technologies to ensure proper functionality and compliance with safety or EMC regulations.

NOTE

Note the instrument's external markings described under [Safety Symbols](#) on page 160.

Ground the Instrument

WARNING

Missing electrical ground

Electrical shock

- If your product is provided with a grounding type power plug, the instrument chassis and cover must be connected to an electrical ground to minimize shock hazard.
- The ground pin must be firmly connected to an electrical ground (safety ground) terminal at the power outlet. Any interruption of the protective (grounding) conductor or disconnection of the protective earth terminal will cause a potential shock hazard that could result in personal injury.

Do Not Operate in an Explosive Atmosphere

WARNING

Presence of flammable gases or fumes

Explosion hazard

- Do not operate the instrument in the presence of flammable gases or fumes.
-

Do Not Remove the Instrument Cover

WARNING

Instrument covers removed

Electrical shock

- Do not remove the instrument cover.
 - Only Agilent authorized personnel are allowed to remove instrument covers. Always disconnect the power cables and any external circuits before removing the instrument cover.
-

Do Not Modify the Instrument

Do not install substitute parts or perform any unauthorized modification to the product. Return the product to an Agilent Sales and Service Office for service and repair to ensure that safety features are maintained.

In Case of Damage

WARNING

Damage to the module

Personal injury (for example electrical shock, intoxication)

- Instruments that appear damaged or defective should be made inoperative and secured against unintended operation until they can be repaired by qualified service personnel.
-

Solvent Information

WARNING

Toxic, flammable and hazardous solvents, samples and reagents

The handling of solvents, samples and reagents can hold health and safety risks.

- When working with these substances observe appropriate safety procedures (for example by wearing goggles, safety gloves and protective clothing) as described in the material handling and safety data sheet supplied by the vendor, and follow good laboratory practice.
- Do not use solvents with an auto-ignition temperature below 200 °C (392 °F). Do not use solvents with a boiling point below 56 °C (133 °F).
- Avoid high vapor concentrations. Keep the solvent temperature at least 40 °C (72 °F) below the boiling point of the solvent used. This includes the solvent temperature in the sample compartment. For the solvents methanol and ethanol keep the solvent temperature at least 25 °C (45 °F) below the boiling point.
- Do not operate the instrument in an explosive atmosphere.
- Do not use solvents of ignition Class IIC according IEC 60079-20-1 (for example, carbon disulfide).
- Reduce the volume of substances to the minimum required for the analysis.
- Do not use bottles that exceed the maximum permissible volume (2.5 L).
- Ground the waste container.
- Regularly check the filling level of the waste container. The residual free volume in the waste container must be large enough to collect the waste liquid.
- To achieve maximal safety, regularly check the tubing for correct installation.

NOTE

For details, see the usage guideline for the solvent cabinet. A printed copy of the guideline has been shipped with the solvent cabinet, electronic copies are available in the InfinityLab LC Series User Documentation or via the Internet.

Recommendations on the Use of Solvents

Observe the following recommendations on the use of solvents.

- Brown glass ware can avoid growth of algae.

Appendix

General Safety Information

- Small particles can permanently block capillaries and valves. Therefore, always filter solvents through 0.22 µm filters.
- Avoid or minimize the use of solvents that may corrode parts in the flow path. Consider specifications for the pH range given for different materials such as flow cells, valve materials etc. and recommendations in subsequent sections.
- Avoid the use of the following steel-corrosive solvents:
 - solutions of alkali halides and their respective acids (for example, lithium iodide, potassium chloride, and so on),
 - high concentrations of inorganic acids like sulfuric acid and nitric acid, especially at higher temperatures (if your chromatography method allows, replace by phosphoric acid or phosphate buffer which are less corrosive against stainless steel),
 - halogenated solvents or mixtures which form radicals and/or acids, for example:

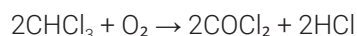

This reaction, in which stainless steel probably acts as a catalyst, occurs quickly with dried chloroform if the drying process removes the stabilizing alcohol,

- chromatographic grade ethers, which can contain peroxides (for example, THF, dioxane, diisopropyl ether) should be filtered through dry aluminium oxide which adsorbs the peroxides,
- solvents containing strong complexing agents (e.g. EDTA),
- mixtures of carbon tetrachloride with 2-propanol or THF.
- Avoid the use of dimethyl formamide (DMF). Polyvinylidene fluoride (PVDF), which is used in leak sensors, is not resistant to DMF.

Safety Symbols

Table 17: Symbols



The apparatus is marked with this symbol when the user shall refer to the instruction manual in order to protect risk of harm to the operator and to protect the apparatus against damage.



Indicates dangerous voltages.

Appendix

General Safety Information



Indicates a protected ground terminal.



The apparatus is marked with this symbol when hot surfaces are available and the user should not touch it when heated up.



Indicates flammable material used. Consult the InfinityLab LC Series User Documentation / User Manual before attempting to install or service this equipment. Follow all safety precautions.



Confirms that a manufactured product complies with all applicable European Community directives. The European Declaration of Conformity is available at: <http://regulations.corporate.agilent.com/DoC/search.htm>



Manufacturing date.



Product Number

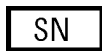

Serial Number



Power symbol indicates On/Off. The apparatus is not completely disconnected from the mains supply when the on/off switch is in the Off position



Pacemaker
Magnets could affect the functioning of pacemakers and implanted heart defibrillators. A pacemaker could switch into test mode and cause illness. A heart defibrillator may stop working. If you wear these devices keep at least 55 mm distance to magnets. Warn others who wear these devices from getting too close to magnets.



Magnetic field
Magnets produce a far-reaching, strong magnetic field. They could damage TVs and laptops, computer hard drives, credit and ATM cards, data storage media, mechanical watches, hearing aids and speakers. Keep magnets at least 25 mm away from devices and objects that could be damaged by strong magnetic fields.



Indicates a pinching or crushing hazard

Appendix

General Safety Information



Indicates a piercing or cutting hazard.



UV radiation hazard

WARNING

A WARNING

alerts you to situations that could cause physical injury or death.

- Do not proceed beyond a warning until you have fully understood and met the indicated conditions.
-

CAUTION

A CAUTION

alerts you to situations that could cause loss of data, or damage of equipment.

- Do not proceed beyond a caution until you have fully understood and met the indicated conditions.
-

Waste Electrical and Electronic Equipment (WEEE) Directive

This product complies with the European WEEE Directive marking requirements. The affixed label indicates that you must not discard this electrical/electronic product in domestic household waste.



NOTE

Do not dispose of in domestic household waste
To return unwanted products, contact your local Agilent office, or see <https://www.agilent.com> for more information.

Radio Interference

Cables supplied by Agilent Technologies are screened to provide optimized protection against radio interference. All cables are in compliance with safety or EMC regulations.

Test and Measurement

If test and measurement equipment is operated with unscreened cables, or used for measurements on open set-ups, the user has to assure that under operating conditions the radio interference limits are still met within the premises.

Korea:

- <https://www.rra.go.kr/selform/ATi-29LCG7180A>

Sound Emission

Sound Pressure

Sound pressure $L_p < 55$ dB(A) according to DIN EN ISO 7779

Schalldruckpegel

Schalldruckpegel $L_p < 55$ dB(A) nach DIN EN ISO 7779

Agilent Technologies on Internet

For the latest information on products and services visit our worldwide web site on the Internet at:

<https://www.agilent.com>

In This Book

This manual contains technical reference information about the Agilent InfinityLab Assist Hub (G7180A), Assist Interface (G7179A) and Assist Control Software (M8780AA). The manual describes the following:

- introduction,
- site requirements and specifications,
- using the modules,
- maintenance,
- parts and materials for maintenance,
- identifying cables,
- hardware information,
- appendix.

www.agilent.com

© Agilent Technologies Inc. 2024-2026
Edition: 03/2026

Document No: D0113047 Rev. A.04

